

Contents

Pump type	Page	Pump type	Page
10A(C)...X001	4	10A(C)...X343	37
10A(C)...X017	5	10A(C)...X348	38
10A(C)...X026	6	10A(C)...X375	39
10A(C)...X027	7	10A(C)...X394	40
10A(C)...X053	8	10A(C)...X400	41
10A(C)...X054	9	10A(C)...X416	42
10A(C)...X055	10	10A(C)...X417	43
10A(C)...X056	11	10A(C)...X418	44
10A(C)...X057	12	10A(C)...X442	45
10A(C)...X115	13	10A(C)...X445	46
10A(C)...X125	14	10A(C)...X459	47
10A(C)...X131	15	10A(C)...X465	48
10A(C)...X135	16	10A(C)...X475	49
10A(C)...X142	17	10A(C)...X476	50
10A(C)...X174	18	10A(C)...X479	51
10A(C)...X175	19	10A(C)...X484	52
10A(C)...X176	20	10A(C)...X485	53
10A(C)...X179	21	10A(C)...X488	54
10A(C)...X181	22	10A(C)...X489	55
10A(C)...X182	23	10A(C)...X491A2A...	56
10A(C)...X230	24	10A(C)...X501	57
10A(C)...X231	25	10A(C)...X502	58
10A(C)...X238	26	10A(C)...X510	59
10A(C)...X244	27	10A(C)...X531	60
10A(C)...X254	28	10A(C)...X551	61
10A(C)...X255	29	10A(C)...X552	62
10A(C)...X257	30	10A(C)...X571	63
10A(C)...X278	31	10A(C)...X575	64
10A(C)...X302	32	10A(C)...X576	65
10A(C)...X303	33	10A(C)...X579	66
10A(C)...X317	34	10A(C)...X594	67
10A(C)...X330	35	10A(C)...X649	68
10A(C)...X340	36		

2x ϕ 5.5 Gr. 00

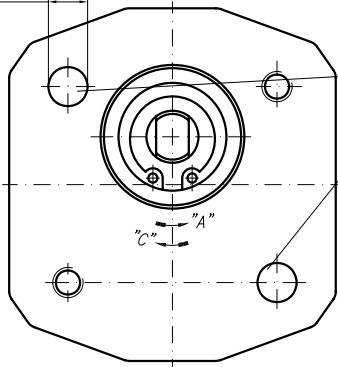

To mount the pump use two screws
M5xL/10.9 (8.8 black)

Torque 5^{+1} Nm

For Pumps at types:

X033	X034	X044	X047	X048W
X051	X052	X063	X065	

And etc.

To mount the pump use two screws
M8xL/10.9 (8.8 black)

Torque 25^{+5} Nm

Gr. 10 2x ϕ 8,5

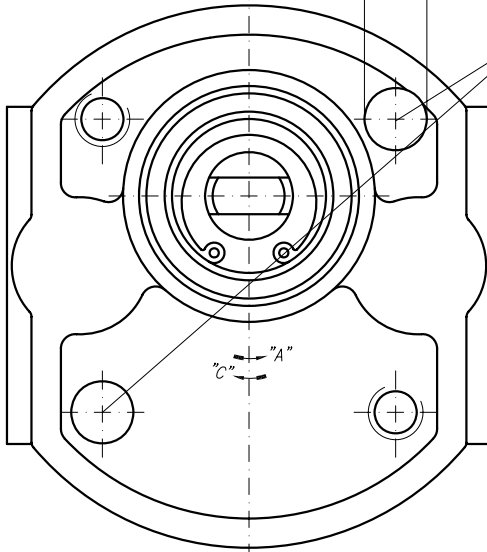

For Pumps at types:

X001	X027	X054	X131	X135
X142	X175	X179	X182	X230
X231	X238	X244	X254	X255
X278	X302	X303	X330	X340
X343	X348	X375	X394	X400
X417	X442	X445	X465	X475
X479	X485	X488	X489	X531
X551	X552	X571	X574	X575
X579	X594	X649	X682	X686

And etc.

To mount the pump use four screws
M10xL/10.9

Torque 45^{+5} Nm

Gr. 20

4x ϕ 11,1

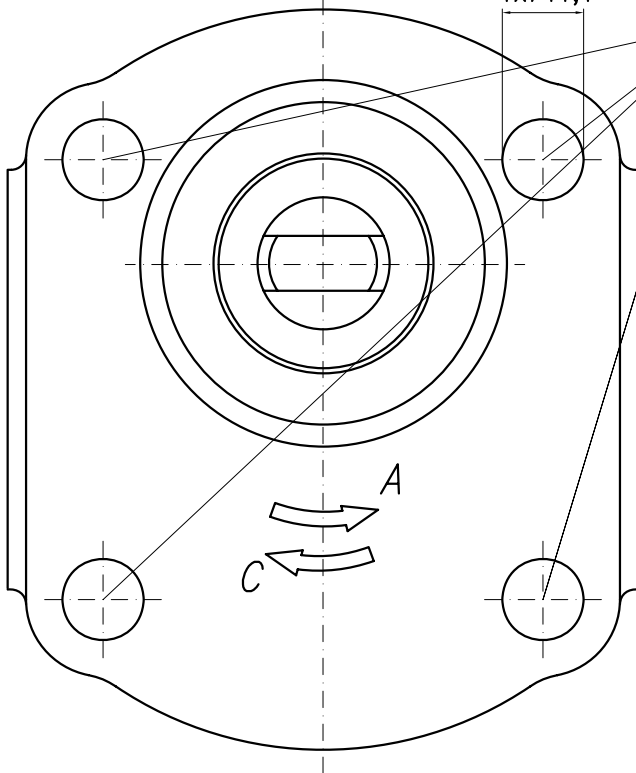

For Pumps at types:

X066	X072	X077	X097	X110
X156	X161	X173	X178	X185
X305	X381	X451	X495	X536
X538	X597	X602	X622	X665

And etc.

To mount the pump use two screws
M10xL/10.9
Torque 45⁺⁵Nm

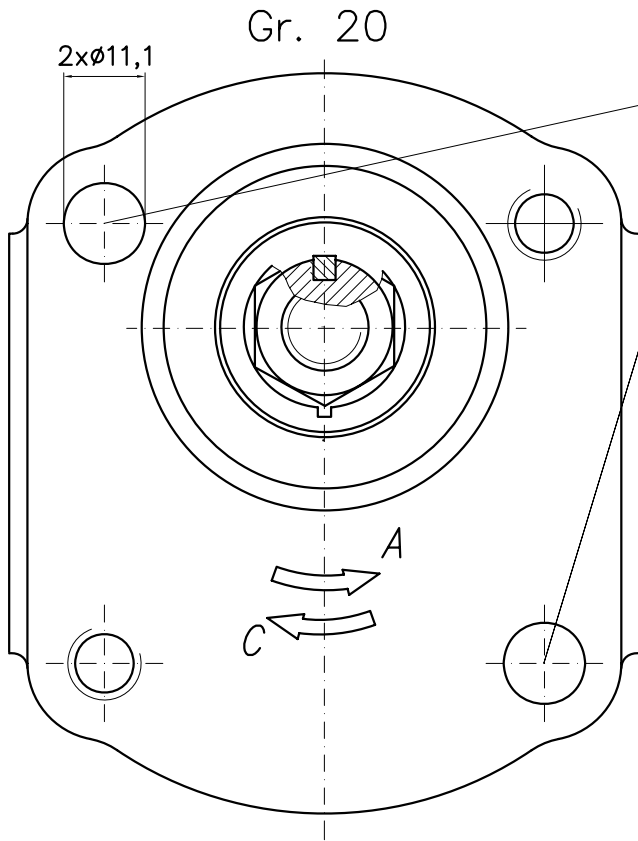

For Pumps at types:				
X007	X074	X083	X087	X091
X095	X096	X127	X128	X132
X147	X153	X170	X178	X187
X205	X295	X449SBA	X540WMS	X567
X573	X847	X857	X867	X877

And etc.

To mount the pump use two screws
M10xL/10.9
Torque 45⁺⁵Nm

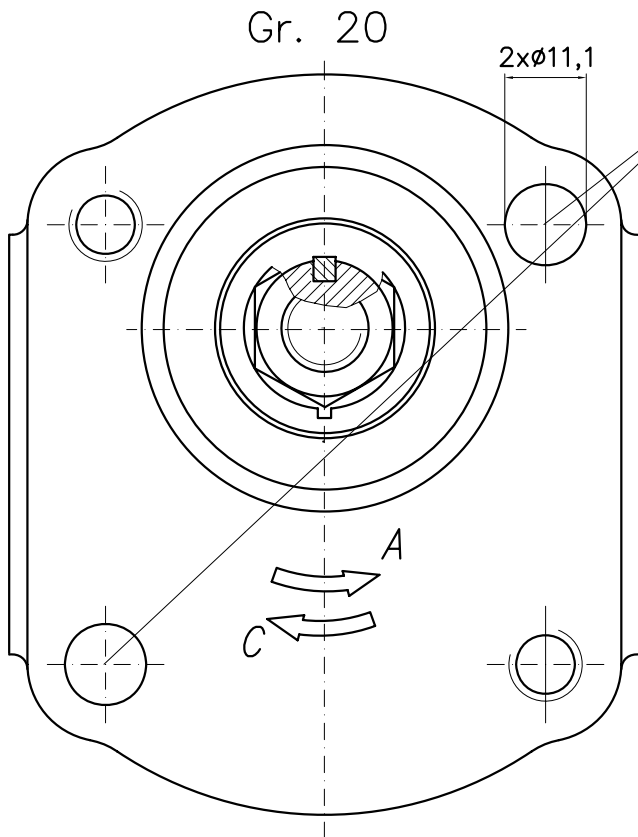

For Pumps at types:				
X008	X296	X368	X402	X403
X496	X528	X583	X586	X588
X652-12SBAW		X653-A1A40W		X776
X803	X843	X848	X868	X878

And etc.

General description

The gear pumps are designed for transforming the mechanical energy as energy of the working liquid (pressure and flow rate). They are simplified in construction and they have a relatively low cost. All these benefits ensure their wide application in the hydraulic systems.

Drive arrangements

The pump drive may be direct or indirect (by gear, chains, or belt transmissions). Both drives should not impose axial or radial forces on the pump shaft. Oldham coupling serrated drive adapters are used with direct drive. For indirect drive refer to the manufacturer.

The gear pumps are designed to work at the conditions mentioned below:

- Working liquid:	hydraulic oils with viscosity	16 ... 200	mm ² /s;
- Degree of filtration:	15 ... 25		µm;
- Ambient temperature range:	- 22 ... 55		°C;
- Fluid temperature range:	- 25 ... 80		°C;
- Inlet pressure, absolute:	0.8 ... 2.2		bar;
- Fluid velocity (suction line)	0,5 ... 1		m/s
- Outlet pressure	up to 250		bar.

The gear pumps made by “Caproni” are produced in 5 different groups: 00, 10, 20 and 20H, 30 and 40. The displacements of the pumps are in the range from 0.25 to 60 cm³.

Group 00	q = 0.25 ... 2	cm ³ ;
Group 10	q = 1 ... 9.8	cm ³ ;
Group 20	q = 4.5 ... 25	cm ³ ;
Group 20H	q = 15 ... 36	cm ³ ;
Group 30	q = 20 ... 60	cm ³ ;
Group 40	q = 46 ... 60	cm ³ .

There are different variants of flanges, shafts and ports for each pump group (standard; Germany; USA ...).

We offer the next variants too:

- tandem pumps;
- pumps with build-in valves;
- reversible pumps;
- reversible gear motors.

Used symbols:

n - speed of rotation	[min ⁻¹];
p - pressure	[bar];
q - displacement	[cm ³];
η - total efficiency $\eta = \eta_q \cdot \eta_{hm}$	[-];
η _{hm} - hydromechanical efficiency	[-];
η _q - volumetric efficiency	[-].

Commonly used formulas:

Flow:	$Q = \frac{q \cdot n \cdot \eta}{1000}$	[l/min]
Torque:	$M \cong \frac{q \cdot p}{20 \cdot \pi}$	[N.m]
Drive power:	$P = \frac{Q \cdot p}{600}$	[kW]

A relationship between the direction of rotation and the place of the inlet and outlet ports of the pumps

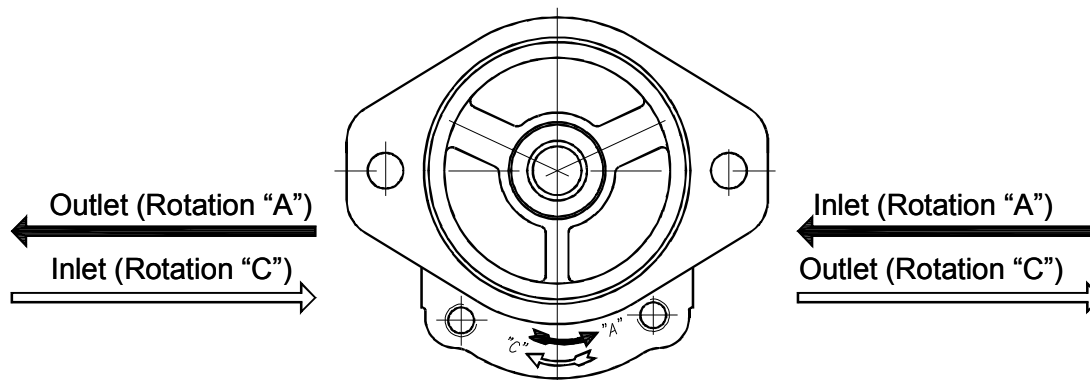

How to order:

Group	Rotation	Displacement code	Drive shaft	Pump code	Ports
00 10 20 30 40	A ↺ C ↻ R ↻		X - Through the front cover Y - Through the both covers	***(*)	- A flange with metric threads P4- A flange with UNC threads M - Metric G - GAS U - SAE J475

Group 00	Group 10	Group 20	Group 20H	Group 30	Group 40
Code cm ³	Code cm ³	Code cm ³	Code cm ³	Code cm ³	Code cm ³
0,25 0,25	1 1	4,5 4,5	15 15	20 20	36 36
0,3 0,3	1,25 1,25	6,3 6,3	16 16	22,5 22,5	42 42
0,5 0,5	1,6 1,6	7* 7	19 19	25 25	46 46
0,75 0,75	2 2	8,2 8,2	22 22	28 28	50 50
1 1	2,5 2,5	10 10	25 25	32 32	55 55
1,25 1,25	2,65* 2,65	11 11,3	28 28	36 36	60 60
1,5 1,5	3,15 3,15	12 12	32 32	42 42	
1,75 1,75	3,65 3,65	14 14	36 36	46 46	
2 2	4,2 4,2	15 15		50 50	
	4,7* 4,7	16 16		55 55	
	5 5	17* 17,3		60 60	
	5,7 5,7	19 19			
	6,1 6,1	22 22			
	7,4 7,4	25 25			
	8* 8	28 28			
	8,5 8,5	32 32			
	9,8 9,8	36 36			

Example: 20A14X073 - Hydraulic gear pump, 20 group, direction of rotation - counter clockwise, displacement 14 cm³, modification 073.

* - These pumps - only under a special order

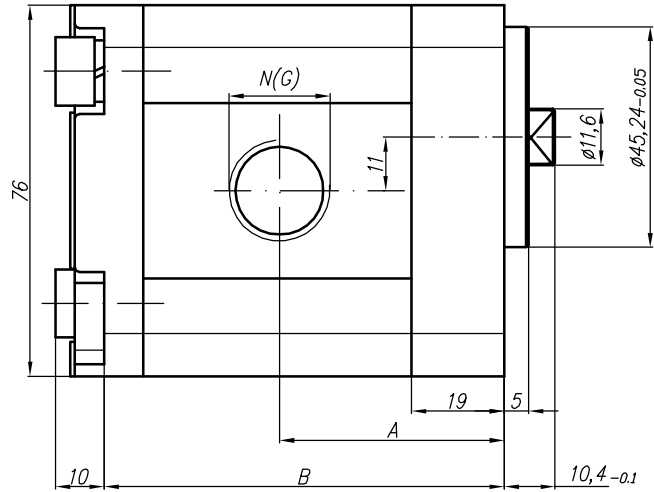
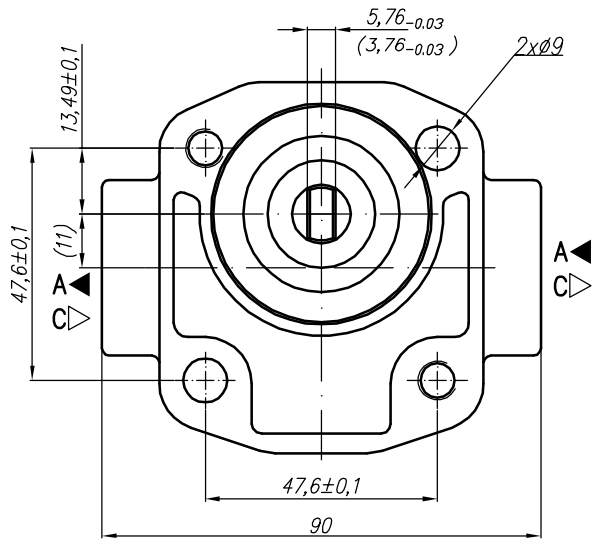

Variants:

- for drive shaft 3,76 - ...001-3
- for G ports - ...001G

Type	Displacement cm ³ /rev	Flow		Pressure P _{nom} bar	max Speed n rpm	Dimension							
		at 1500 rpm l/min	at max rpm l/min			A mm	B mm	Inlet			Outlet		
								G	N	U	G	N	U
10A(C)1X001	1	1,40	3,26	250	3500	40,1	69,1	G1/2	1/2" NPTF-14		G1/2	1/2" NPTF-14	
10A(C)1,25X001	1,25	1,74	4,07	250	3500	40,6	70,1						
10A(C)1,6X001	1,6	2,23	5,21	250	3500	41,3	71,5						
10A(C)2X001	2	2,82	6,58	250	3500	42,1	73,2						
10A(C)2,5X001	2,5	3,53	8,23	250	3500	43,1	75,2						
* 10A(C)2,65X001	2,65	3,74	8,72	250	3500	43,4	75,8						
10A(C)3,15X001	3,15	4,44	10,36	250	3500	44,5	77,8						
10A(C)3,65X001	3,65	5,15	12,01	250	3500	45,4	79,8						
10A(C)4,2X001	4,2	5,92	13,82	250	3500	46,5	82,0						
* 10A(C)4,7X001	4,7	6,63	15,46	250	3500	47,5	84,1						
10A(C)5X001	5	7,05	14,10	250	3000	48,1	85,2						
10A(C)5,7X001	5,7	8,12	16,25	200	3000	49,5	88,0						
10A(C)6,1X001	6,1	8,69	14,49	200	2500	50,4	89,8						
10A(C)7,4X001	7,4	10,55	17,58	180	2500	53,1	95,3						
* 10A(C)8X001	8	11,40	15,20	150	2000	54,4	97,7						
10A(C)8,5X001	8,5	12,11	16,15	150	2000	55,4	99,8						
10A(C)9,8X001	9,8	13,97	18,62	120	2000	58,0	105,0						

* - These pumps - only under a special order

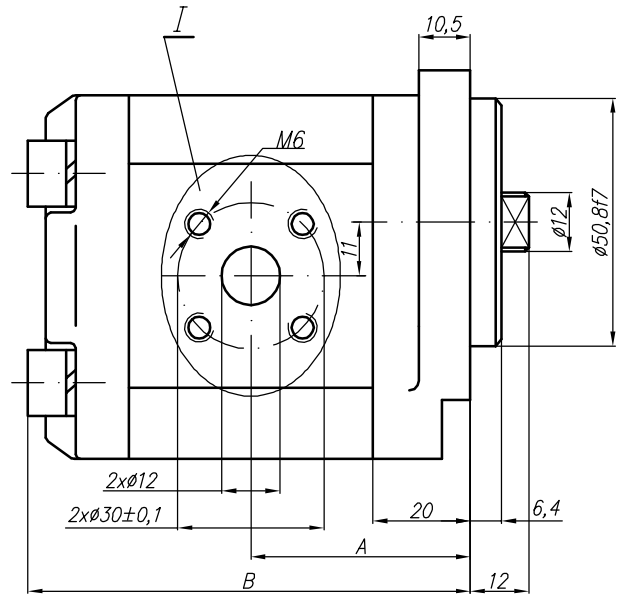
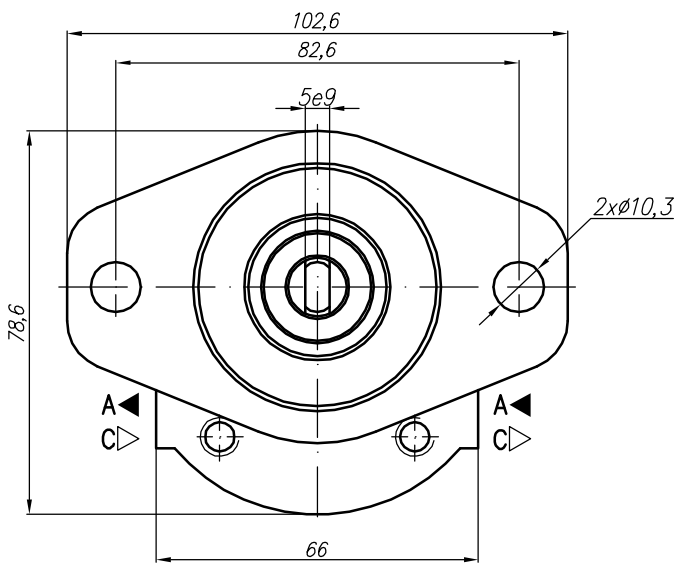

I – variants

Variants:

- ...X017 - Normal version (flange);
- ...X017M - for M ports (see the picture I and the table below);
- ...X017G - for G ports (see the picture I and the table below);
- ...X017U - for U ports (see the picture I and the table below).

Variant M

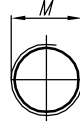

Variant G

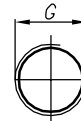

Variant U (SAEJ475 (ISO R725))

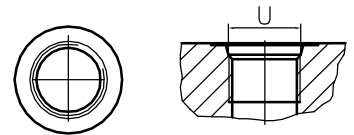

Type	Displacement cm ³ /rev	Flow		Pressure P _{nom} bar	max Speed n rpm	Dimension							
		at 1500 rpm l/min	at max rpm l/min			A mm	B mm	Inlet			Outlet		
								M	G	U	M	G	U
10A(C)1X017	1	1,40	3,26	250	3500	41,1	83						
10A(C)1,25X017	1,25	1,74	4,07	250	3500	41,5	84						
10A(C)1,6X017	1,6	2,23	5,21	250	3500	42,3	85,6						
10A(C)2X017	2	2,82	6,58	250	3500	43,1	87,2						
10A(C)2,5X017	2,5	3,53	8,23	250	3500	44,1	89,2						
* 10A(C)2,65X017	2,65	3,74	8,72	250	3500	44,4	89,8						
10A(C)3,15X017	3,15	4,44	10,36	250	3500	45,5	91,8						
10A(C)3,65X017	3,65	5,15	12,01	250	3500	46,4	93,9						
10A(C)4,2X017	4,2	5,92	13,82	250	3500	47,5	96,1						
* 10A(C)4,7X017	4,7	6,63	15,46	250	3500	48,5	98						
10A(C)5X017	5	7,05	14,10	250	3000	49,1	99,2						
10A(C)5,7X017	5,7	8,12	16,25	200	3000	50,5	102						
10A(C)6,1X017	6,1	8,69	14,49	200	2500	51,4	103,8						
10A(C)7,4X017	7,4	10,55	17,58	180	2500	54,1	109,2						
* 10A(C)8X017	8	11,40	15,20	150	2000	55,4	111,7						
10A(C)8,5X017	8,5	12,11	16,15	150	2000	56,4	113,7						
10A(C)9,8X017	9,8	13,97	18,62	120	2000	59	119						

* - These pumps - only under a special order

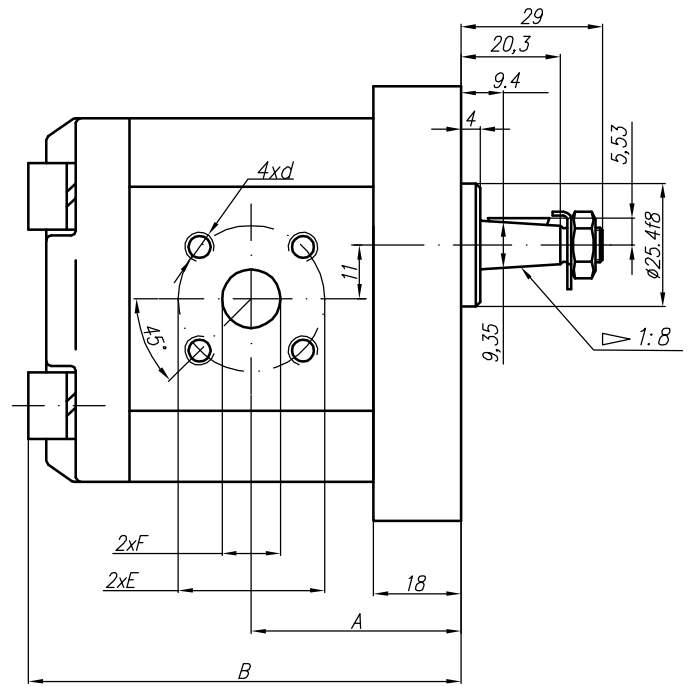
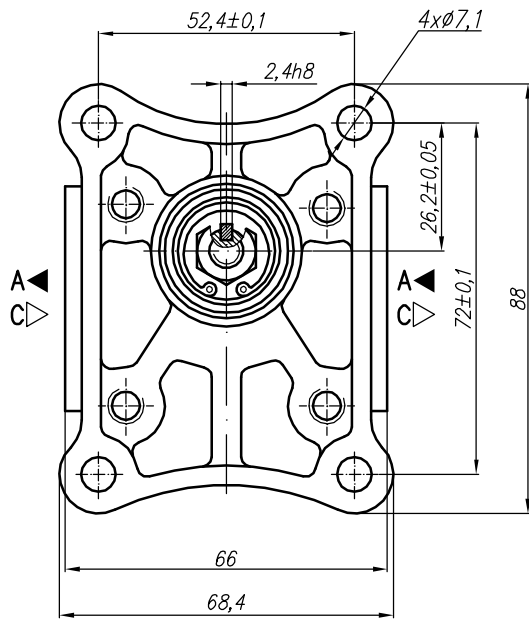

Type	Displacement cm ³ /rev	Flow		Pressure P _{nom} bar	max Speed n rpm	Dimension							
		at 1500 rpm l/min	at max rpm l/min			A mm	B mm	Inlet			Outlet		
								E	F	d	M	G	U
10A(C)1X026	1	1,40	3,26	250	3500	39,1	81						
10A(C)1,25X026	1,25	1,74	4,07	250	3500	39,5	82						
10A(C)1,6X026	1,6	2,23	5,21	250	3500	40,3	83,6						
10A(C)2X026	2	2,82	6,58	250	3500	41,1	85,2						
10A(C)2,5X026	2,5	3,53	8,23	250	3500	42,1	87,2						
* 10A(C)2,65X026	2,65	3,74	8,72	250	3500	42,4	87,8						
10A(C)3,15X026	3,15	4,44	10,36	250	3500	43,5	89,8						
10A(C)3,65X026	3,65	5,15	12,01	250	3500	44,4	91,9						
10A(C)4,2X026	4,2	5,92	13,82	250	3500	45,5	94,1	∅30	∅12	M6	∅30	∅12	M6
* 10A(C)4,7X026	4,7	6,63	15,46	250	3500	46,1	96						
10A(C)5X026	5	7,05	14,10	250	3000	47,1	97,2						
10A(C)5,7X026	5,7	8,12	16,25	200	3000	48,5	100,1						
10A(C)6,1X026	6,1	8,69	14,49	200	2500	49,4	101,8						
10A(C)7,4X026	7,4	10,55	17,58	180	2500	52,1	107,2						
* 10A(C)8X026	8	11,40	15,20	150	2000	53,4	109,7						
10A(C)8,5X026	8,5	12,11	16,15	150	2000	54,4	111,7						
10A(C)9,8X026	9,8	13,97	18,62	120	2000	57	117						

* - These pumps - only under a special order

Rotation "A" - (anticlockwise)

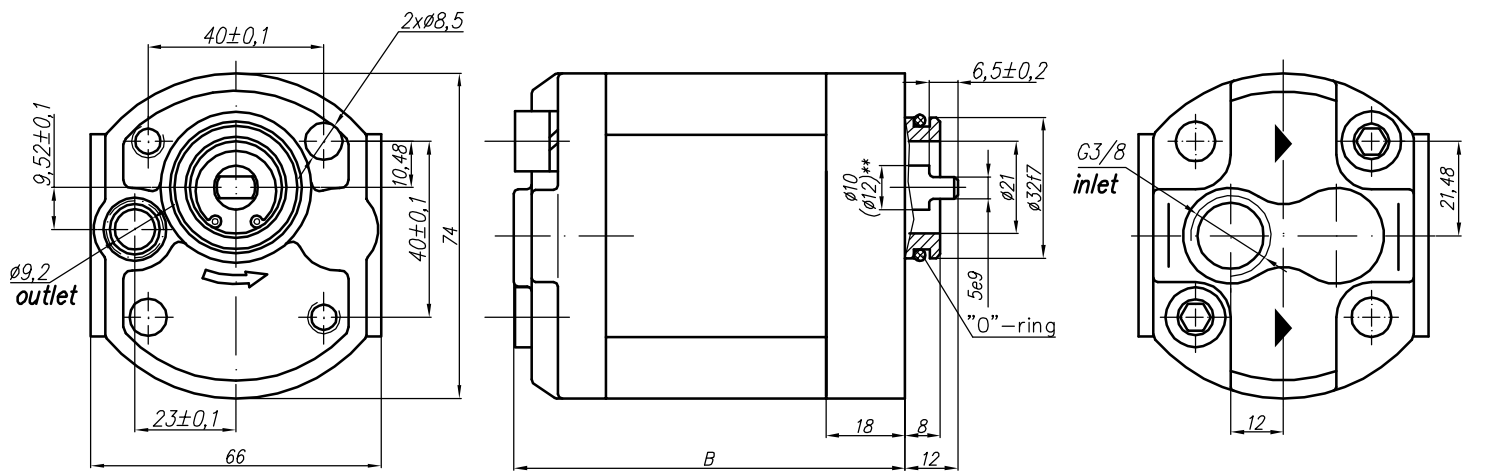

Rotation "C" - (clockwise)

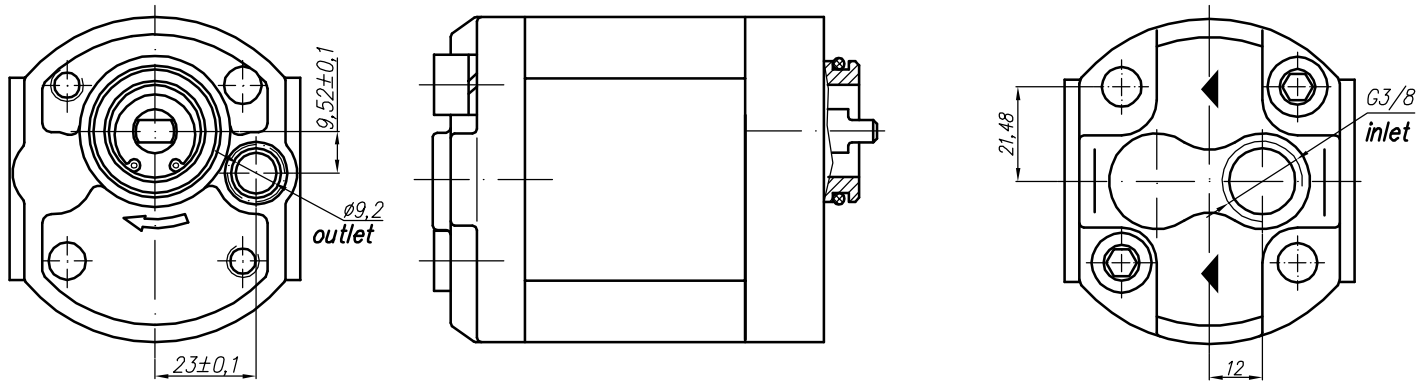

Type	Displacement cm ³ /rev	Flow		Pressure P _{nom} bar	max Speed n rpm	Dimension							
		at 1500 rpm l/min	at max rpm l/min			Inlet			Outlet				
						A mm	B mm	M	G	U	M	G	U
10A(C)1X027	1	1,40	3,26	250	3500	71	81	G 3/8" - A					
10A(C)1,25X027	1,25	1,74	4,07	250	3500	72	82						
10A(C)1,6X027	1,6	2,23	5,21	250	3500	73,6	83,6						
10A(C)2X027	2	2,82	6,58	250	3500	75,2	85,2						
10A(C)2,5X027	2,5	3,53	8,23	250	3500	77,2	87,2						
* 10A(C)2,65X027	2,65	3,74	8,72	250	3500	77,8	87,8						
10A(C)3,15X027	3,15	4,44	10,36	250	3500	79,8	89,8						
10A(C)3,65X027	3,65	5,15	12,01	250	3500	81,9	91,9						
10A(C)4,2X027	4,2	5,92	13,82	250	3500	84,1	94,1						
* 10A(C)4,7X027	4,7	6,63	15,46	250	3500	87,1	97,1						
10A(C)5X027	5	7,05	14,10	250	3000	87,2	97,2						
10A(C)5,7X027	5,7	8,12	16,25	200	3000	90,1	100,1						
10A(C)6,1X027	6,1	8,69	14,49	200	2500	91,8	101,8						
10A(C)7,4X027	7,4	10,55	17,58	180	2500	97,2	107,2						
* 10A(C)8X027	8	11,40	15,20	150	2000	99,7	109,7						
10A(C)8,5X027	8,5	12,11	16,15	150	2000	101,7	111,7						
10A(C)9,8X027	9,8	13,97	18,62	120	2000	107	117						

* - These pumps - only under a special order

** - For a shaft with dia 12 see the pump 302 (p. 32)

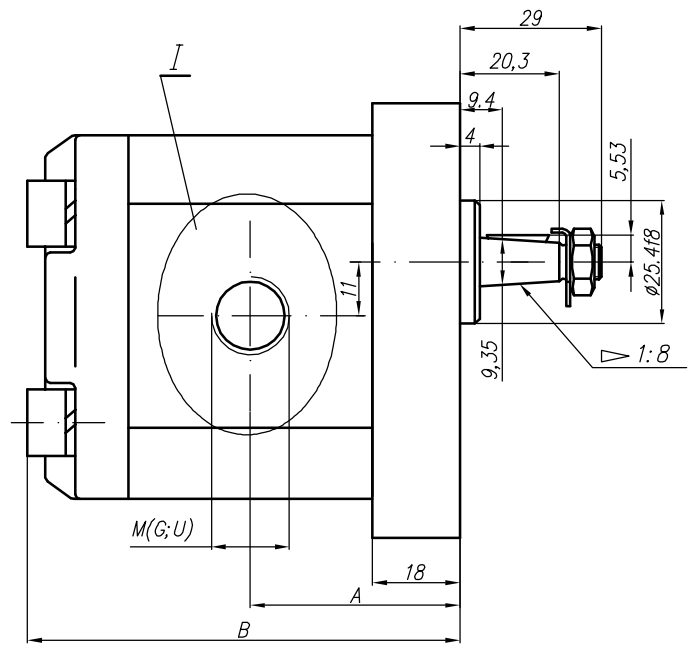
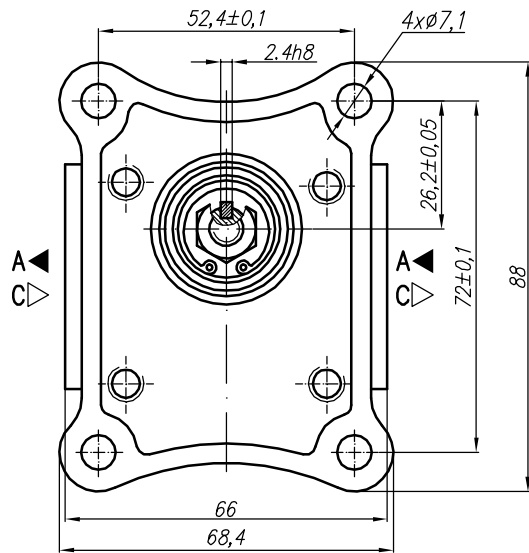

I – variants

Variants:

...X053M - for M ports (see the picture I and the table below);

...X053G - for G ports (see the picture I and the table below);

...X053U - for U ports (see the picture I and the table below).

Variant M

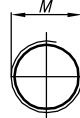

Variant G



Variant U (SAEJ475 (ISO R725))

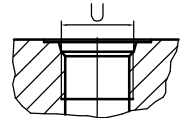

Type	Displacement cm ³ /rev	Flow		Pressure P _{nom} bar	max Speed n rpm	Dimension							
		at 1500 rpm l/min	at max rpm l/min			A mm	B mm	Inlet			Outlet		
								M	G	U	M	G	U
10A(C)1X053	1	1,40	3,26	250	3500	39,1	81						
10A(C)1,25X053	1,25	1,74	4,07	250	3500	39,5	82						
10A(C)1,6X053	1,6	2,23	5,21	250	3500	40,3	83,6						
10A(C)2X053	2	2,82	6,58	250	3500	41,1	85,2						
10A(C)2,5X053	2,5	3,53	8,23	250	3500	42,1	87,2						
* 10A(C)2,65X053	2,65	3,74	8,72	250	3500	42,4	87,8						
10A(C)3,15X053	3,15	4,44	10,36	250	3500	43,5	89,8						
10A(C)3,65X053	3,65	5,15	12,01	250	3500	44,4	91,9						
10A(C)4,2X053	4,2	5,92	13,82	250	3500	45,5	94,1						
* 10A(C)4,7X053	4,7	6,63	15,46	250	3500	46,1	96						
10A(C)5X053	5	7,05	14,10	250	3000	47,1	97,2						
10A(C)5,7X053	5,7	8,12	16,25	200	3000	48,5	100,1						
10A(C)6,1X053	6,1	8,69	14,49	200	2500	49,4	101,8						
10A(C)7,4X053	7,4	10,55	17,58	180	2500	52,1	107,2						
* 10A(C)8X053	8	11,40	15,20	150	2000	53,4	109,7						
10A(C)8,5X053	8,5	12,11	16,15	150	2000	54,4	111,7						
10A(C)9,8X053	9,8	13,97	18,62	120	2000	57	117						

* - These pumps - only under a special order

Rotation "A" - (anticlockwise)

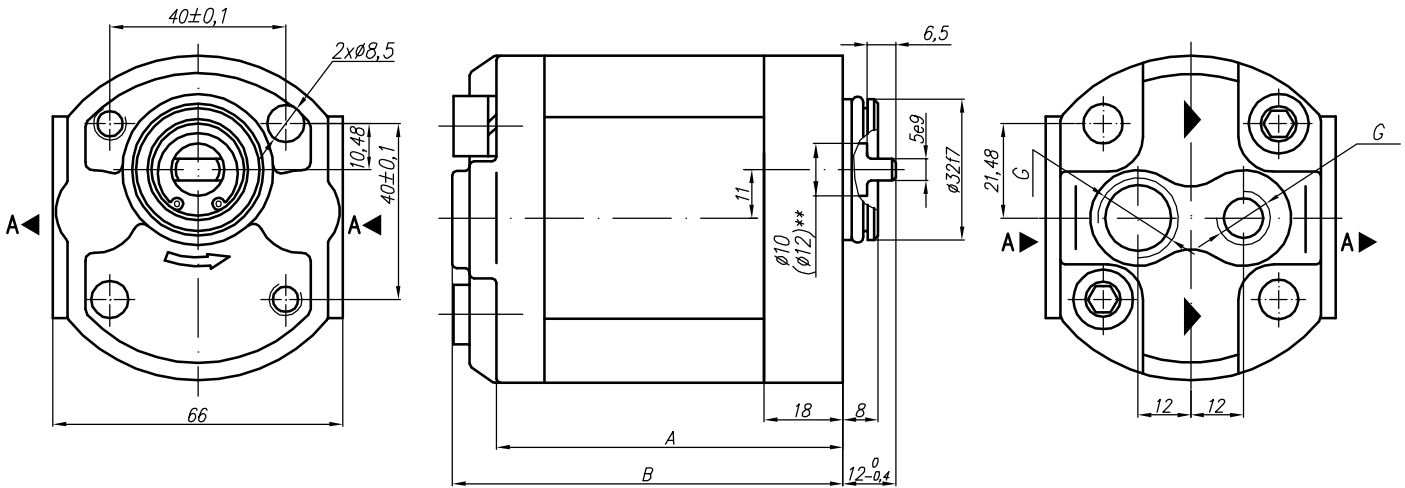

Rotation "C" - (clockwise)

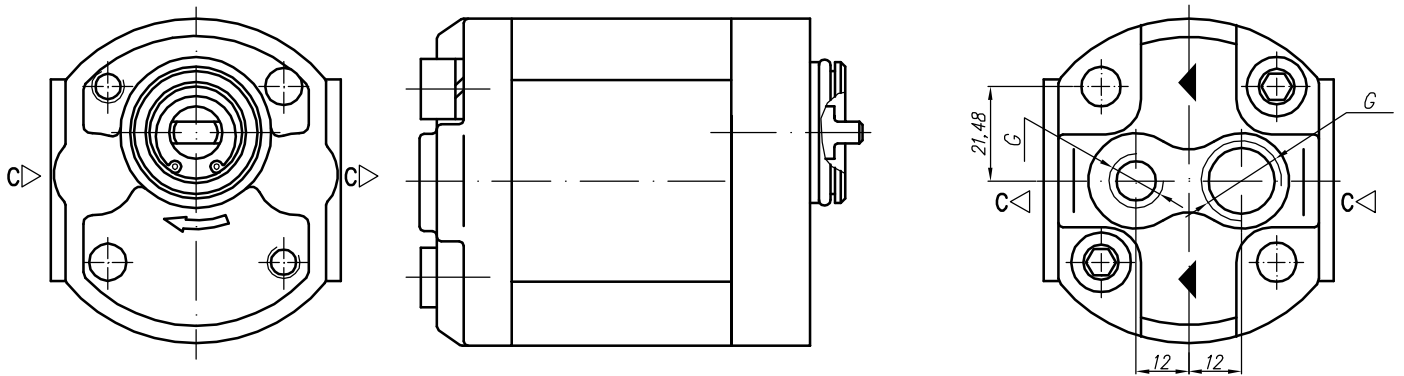

Type	Displacement cm ³ /rev	Flow		Pressure P _{nom} bar	max Speed n rpm	Dimension							
		at 1500 rpm l/min	at max rpm l/min			Inlet			Outlet				
						A mm	B mm	M	G	U	M	G	U
10A(C)1X054	1	1,40	3,26	250	3500	71	81	G 3/8" - A				G 1/4" - A	
10A(C)1,25X054	1,25	1,74	4,07	250	3500	72	82						
10A(C)1,6X054	1,6	2,23	5,21	250	3500	73,6	83,6						
10A(C)2X054	2	2,82	6,58	250	3500	75,2	85,2						
10A(C)2,5X054	2,5	3,53	8,23	250	3500	77,2	87,2						
* 10A(C)2,65X054	2,65	3,74	8,72	250	3500	77,8	87,8						
10A(C)3,15X054	3,15	4,44	10,36	250	3500	79,8	89,8						
10A(C)3,65X054	3,65	5,15	12,01	250	3500	81,9	91,9						
10A(C)4,2X054	4,2	5,92	13,82	250	3500	84,1	94,1						
* 10A(C)4,7X054	4,7	6,63	15,46	250	3500	87,1	97,1						
10A(C)5X054	5	7,05	14,10	250	3000	87,2	97,2						
10A(C)5,7X054	5,7	8,12	16,25	200	3000	90,1	100,1						
10A(C)6,1X054	6,1	8,69	14,49	200	2500	91,8	101,8						
10A(C)7,4X054	7,4	10,55	17,58	180	2500	97,2	107,2						
* 10A(C)8X054	8	11,40	15,20	150	2000	99,7	109,7						
10A(C)8,5X054	8,5	12,11	16,15	150	2000	101,7	111,7						
10A(C)9,8X054	9,8	13,97	18,62	120	2000	107	117						

* - These pumps - only under a special order

** - Shaft dia is 10 mm for displ. 1 ... 6,1 ccm and 12 mm for displ. 7,4 ccm and more

Rotation "A" - (anticlockwise)

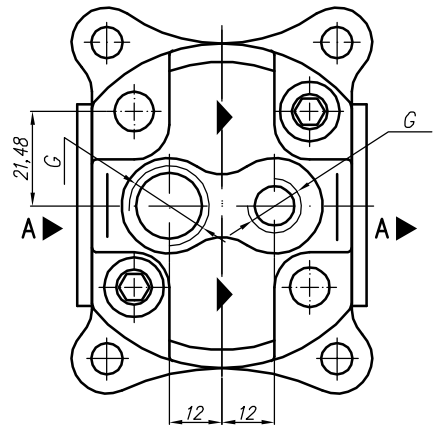
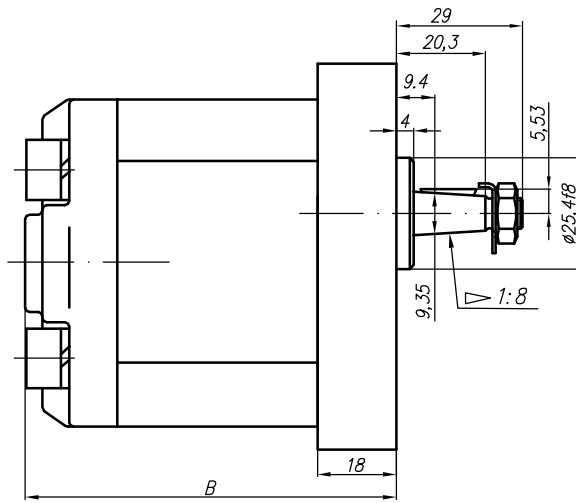
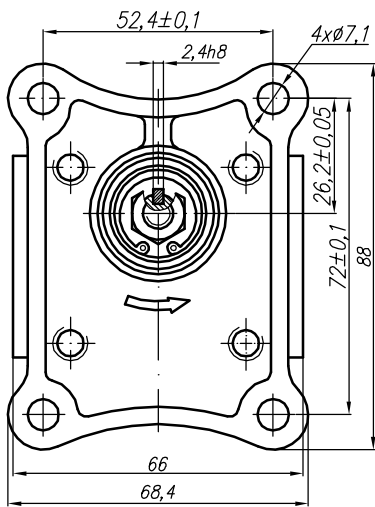

Rotation "C" - (clockwise)

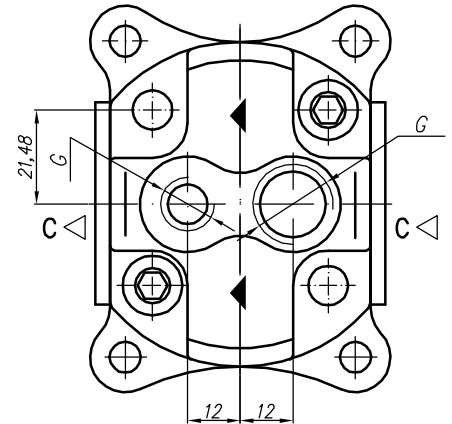
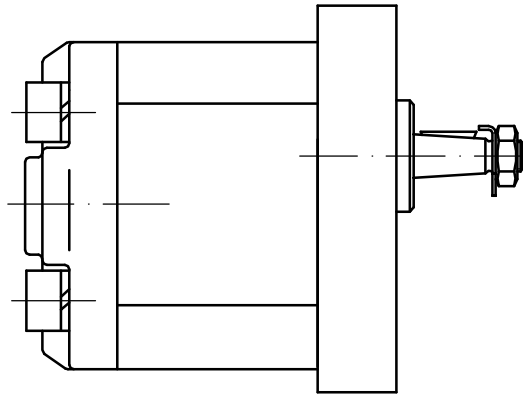
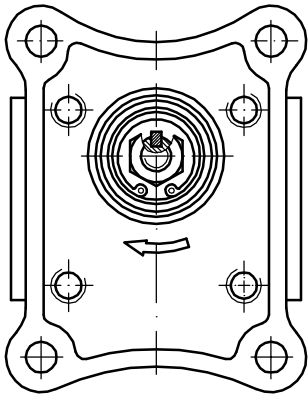

Type	Displacement cm ³ /rev	Flow		Pressure P _{nom} bar	max Speed n rpm	Dimension							
		at 1500 rpm l/min	at max rpm l/min			A mm	B mm	Inlet			Outlet		
								M	G	U	M	G	U
10A(C)1X055	1	1,40	3,26	250	3500	71	81	G 3/8" - A				G 1/4" - A	
10A(C)1,25X055	1,25	1,74	4,07	250	3500	72	82						
10A(C)1,6X055	1,6	2,23	5,21	250	3500	73,6	83,6						
10A(C)2X055	2	2,82	6,58	250	3500	75,2	85,2						
10A(C)2,5X055	2,5	3,53	8,23	250	3500	77,2	87,2						
* 10A(C)2,65X055	2,65	3,74	8,72	250	3500	77,8	87,8						
10A(C)3,15X055	3,15	4,44	10,36	250	3500	79,8	89,8						
10A(C)3,65X055	3,65	5,15	12,01	250	3500	81,9	91,9						
10A(C)4,2X055	4,2	5,92	13,82	250	3500	84,1	94,1						
* 10A(C)4,7X055	4,7	6,63	15,46	250	3500	87,1	97,1						
10A(C)5X055	5	7,05	14,10	250	3000	87,2	97,2						
10A(C)5,7X055	5,7	8,12	16,25	200	3000	90,1	100,1						
10A(C)6,1X055	6,1	8,69	14,49	200	2500	91,8	101,8						
10A(C)7,4X055	7,4	10,55	17,58	180	2500	97,2	107,2						
* 10A(C)8X055	8	11,40	15,20	150	2000	99,7	109,7						
10A(C)8,5X055	8,5	12,11	16,15	150	2000	101,7	111,7						
10A(C)9,8X055	9,8	13,97	18,62	120	2000	107	117						

* - These pumps - only under a special order

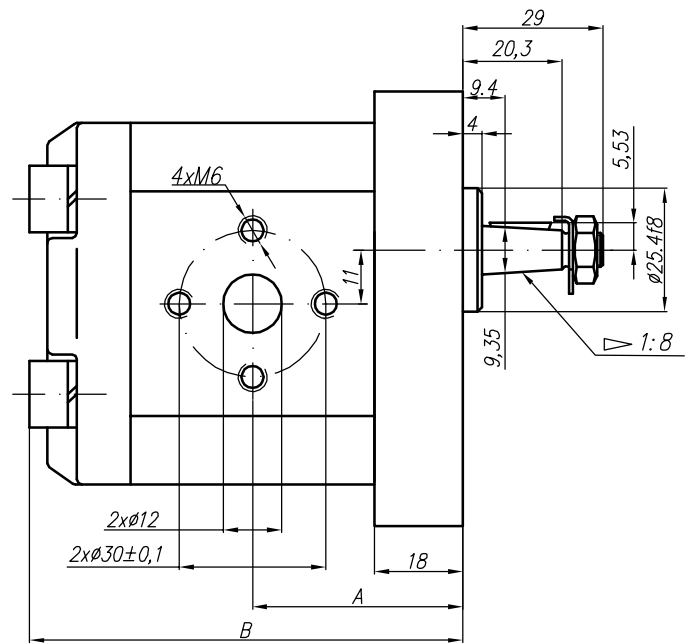
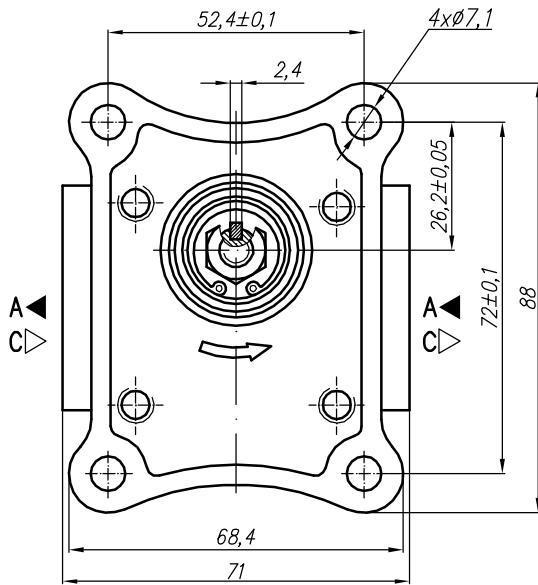

Type	Displacement cm ³ /rev	Flow		Pressure P _{nom} bar	max Speed n rpm	Dimension							
		at 1500 rpm l/min	at max rpm l/min			Inlet		Outlet					
						A mm	B mm	M	G	U	M	G	U
10A(C)1X056	1	1,40	3,26	250	3500	39,1	81						
10A(C)1,25X056	1,25	1,74	4,07	250	3500	39,5	82						
10A(C)1,6X056	1,6	2,23	5,21	250	3500	40,3	83,6						
10A(C)2X056	2	2,82	6,58	250	3500	41,1	85,2						
10A(C)2,5X056	2,5	3,53	8,23	250	3500	42,1	87,2						
* 10A(C)2,65X056	2,65	3,74	8,72	250	3500	42,4	87,8						
10A(C)3,15X056	3,15	4,44	10,36	250	3500	43,5	89,8						
10A(C)3,65X056	3,65	5,15	12,01	250	3500	44,4	91,9						
10A(C)4,2X056	4,2	5,92	13,82	250	3500	45,5	94,1						
* 10A(C)4,7X056	4,7	6,63	15,46	250	3500	46,1	96						
10A(C)5X056	5	7,05	14,10	250	3000	47,1	97,2						
10A(C)5,7X056	5,7	8,12	16,25	200	3000	48,5	100,1						
10A(C)6,1X056	6,1	8,69	14,49	200	2500	49,4	101,8						
10A(C)7,4X056	7,4	10,55	17,58	180	2500	52,1	107,2						
* 10A(C)8X056	8	11,40	15,20	150	2000	53,4	109,7						
10A(C)8,5X056	8,5	12,11	16,15	150	2000	54,4	111,7						
10A(C)9,8X056	9,8	13,97	18,62	120	2000	57	117						

* - These pumps - only under a special order

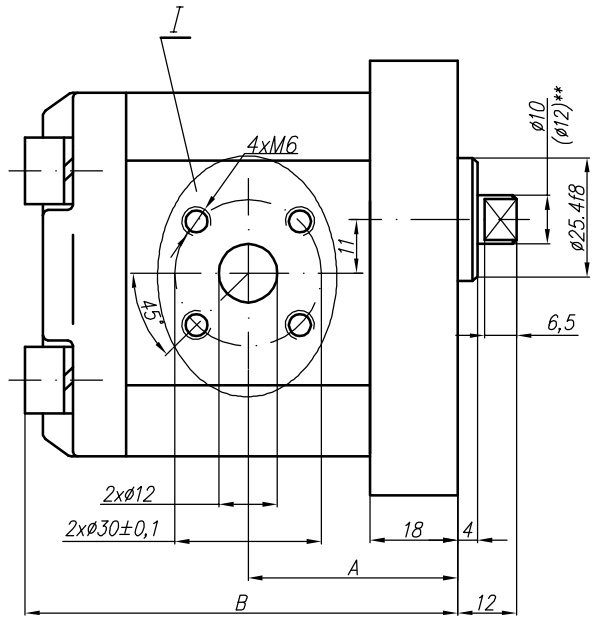
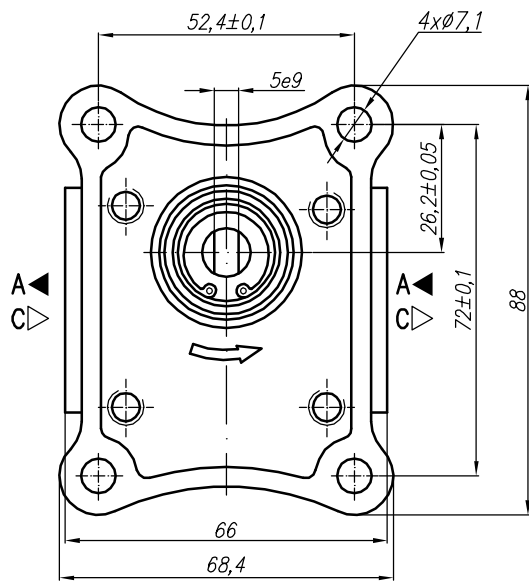

I – variants

Variants:

- ...X057 - Normal version (flange);
- ...X057M - for M ports (see the picture I and the table below);
- ...X057G - for G ports (see the picture I and the table below);
- ...X057U - for U ports (see the picture I and the table below).

Variant M

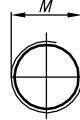

Variant G

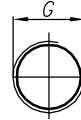

Variant U (SAEJ475 (ISO R725))

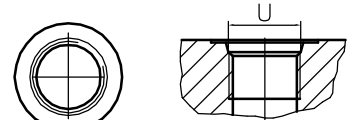

Type	Displacement cm ³ /rev	Flow		Pressure P _{nom} bar	max Speed n rpm	Dimension							
		at 1500 rpm l/min	at max rpm l/min			A mm	B mm	Inlet			Outlet		
								M	G	U	M	G	U
10A(C)1X057	1	1,40	3,26	250	3500	39,1	81	M16x1,5	G 3/8" - A	3/4" - 16UNF - 2B	M16x1,5	G 3/8" - A	9/16" - 18UNF - 2B
10A(C)1,25X057	1,25	1,74	4,07	250	3500	39,5	82						
10A(C)1,6X057	1,6	2,23	5,21	250	3500	40,3	83,6						
10A(C)2X057	2	2,82	6,58	250	3500	41,1	85,2						
10A(C)2,5X057	2,5	3,53	8,23	250	3500	42,1	87,2						
* 10A(C)2,65X057	2,65	3,74	8,72	250	3500	42,4	87,8	M20x1,5	G 1/2" - A	3/4" - 16UNF - 2B	M16x1,5	G 3/8" - A	9/16" - 18UNF - 2B
10A(C)3,15X057	3,15	4,44	10,36	250	3500	43,5	89,8						
10A(C)3,65X057	3,65	5,15	12,01	250	3500	44,4	91,9						
10A(C)4,2X057	4,2	5,92	13,82	250	3500	45,5	94,1						
* 10A(C)4,7X057	4,7	6,63	15,46	250	3500	46,1	96						
10A(C)5X057	5	7,05	14,10	250	3000	47,1	97,2	M22x1,5	G 1/2" - A	7/8" - 14UNF	M18x1,5	G 3/8" - A	3/4" - 16UNF
10A(C)5,7X057	5,7	8,12	16,25	200	3000	48,5	100,1						
10A(C)6,1X057	6,1	8,69	14,49	180	2500	49,4	101,8						
10A(C)7,4X057	7,4	10,55	17,58	180	2500	52,1	107,2						
* 10A(C)8X057	8	11,40	15,20	150	2000	53,4	109,7						
10A(C)8,5X057	8,5	12,11	16,15	150	2000	54,4	111,7	M22x1,5	G 1/2" - A	7/8" - 14UNF	M18x1,5	G 3/8" - A	3/4" - 16UNF
10A(C)9,8X057	9,8	13,97	18,62	120	2000	57	117						

* - These pumps - only under a special order

** - Shaft dia is 10 mm for displ. 1 ... 6,1 ccm and 12 mm for displ. 7,4 ccm and more

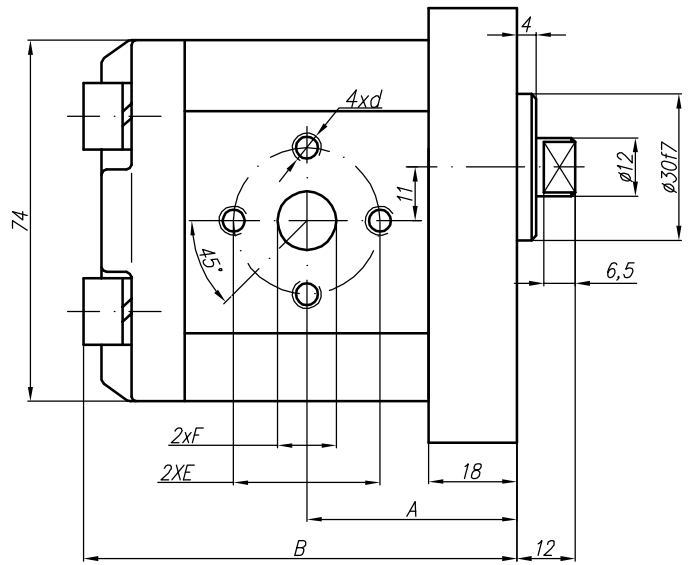
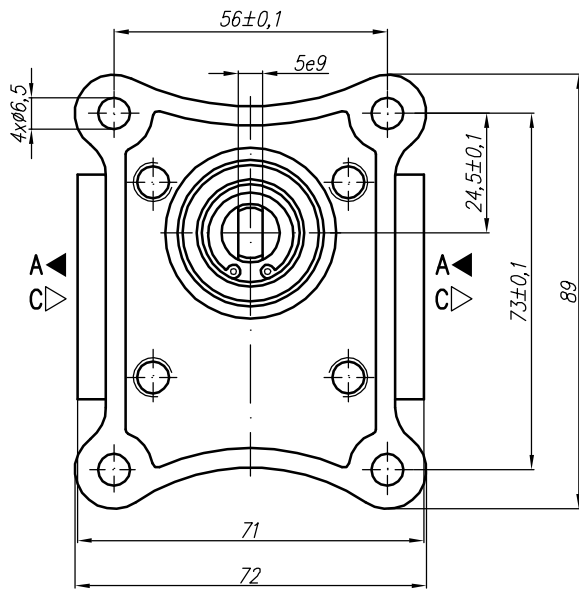

Type	Displacement cm ³ /rev	Flow		Pressure P _{nom} bar	max Speed n rpm	Dimension							
		at 1500 rpm l/min	at max rpm l/min			A mm	B mm	Inlet			Outlet		
								E	F	d	E	F	d
10A(C)1X115	1	1,40	3,26	250	3500	39,1	81	∅30	∅12	M6	∅30	∅12	M6
10A(C)1,25X115	1,25	1,74	4,07	250	3500	39,5	82						
10A(C)1,6X115	1,6	2,23	5,21	250	3500	40,3	83,6						
10A(C)2X115	2	2,82	6,58	250	3500	41,1	85,2						
10A(C)2,5X115	2,5	3,53	8,23	250	3500	42,1	87,2						
* 10A(C)2,65X115	2,65	3,74	8,72	250	3500	42,4	87,8						
10A(C)3,15X115	3,15	4,44	10,36	250	3500	43,5	89,8						
10A(C)3,65X115	3,65	5,15	12,01	250	3500	44,4	91,9						
10A(C)4,2X115	4,2	5,92	13,82	250	3500	45,5	94,1						
* 10A(C)4,7X115	4,7	6,63	15,46	250	3500	46,1	96						
10A(C)5X115	5	7,05	14,10	250	3000	47,1	97,2						
10A(C)5,7X115	5,7	8,12	16,25	200	3000	48,5	100,1						
10A(C)6,1X115	6,1	8,69	14,49	200	2500	49,4	101,8						
10A(C)7,4X115	7,4	10,55	17,58	180	2500	52,1	107,2						
* 10A(C)8X115	8	11,40	15,20	150	2000	53,4	109,7						
10A(C)8,5X115	8,5	12,11	16,15	150	2000	54,4	111,7						
10A(C)9,8X115	9,8	13,97	18,62	120	2000	57	117						

* - These pumps - only under a special order

Rotation "A" - (anticlockwise)

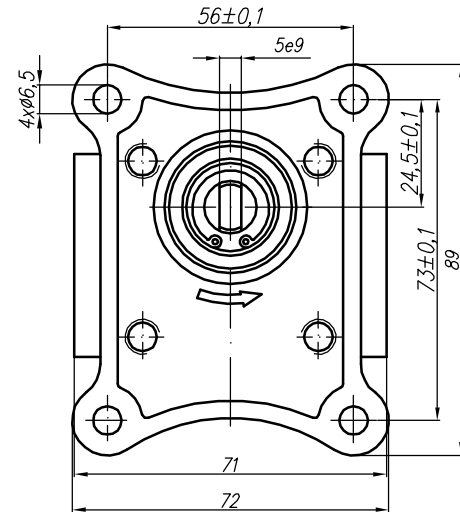
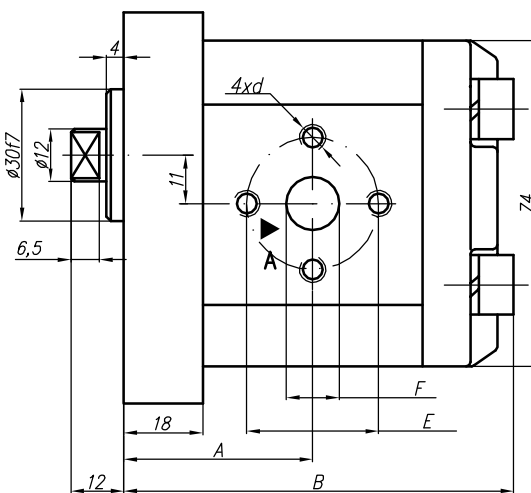
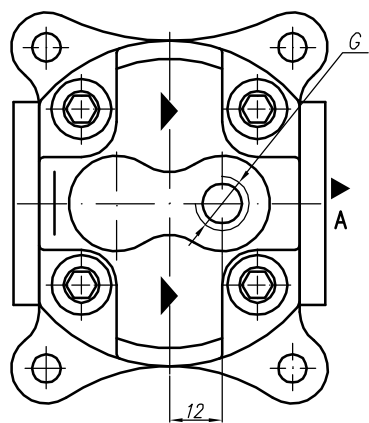

Rotation "C" - (clockwise)

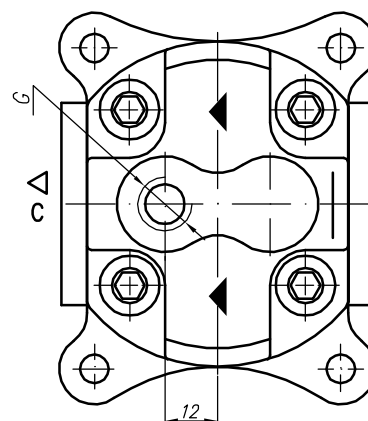
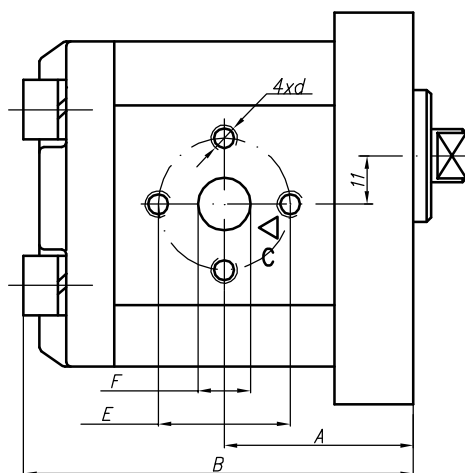
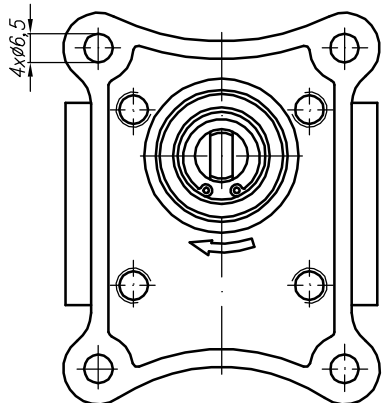

Type	Displacement cm ³ /rev	Flow		Pressure P _{nom} bar	max Speed n rpm	Dimension						
		at 1500 rpm l/min	at max rpm l/min			A mm	B mm	Inlet			Outlet	
						E	F	d	M	G	U	
10A(C)1X125	1	1,40	3,26	250	3500	39,1	81					
10A(C)1,25X125	1,25	1,74	4,07	250	3500	39,5	82					
10A(C)1,6X125	1,6	2,23	5,21	250	3500	40,3	83,6					
10A(C)2X125	2	2,82	6,58	250	3500	41,1	85,2					
10A(C)2,5X125	2,5	3,53	8,23	250	3500	42,1	87,2					
* 10A(C)2,65X125	2,65	3,74	8,72	250	3500	42,4	87,8					
10A(C)3,15X125	3,15	4,44	10,36	250	3500	43,5	89,8					
10A(C)3,65X125	3,65	5,15	12,01	250	3500	44,4	91,9					
10A(C)4,2X125	4,2	5,92	13,82	250	3500	45,5	94,1	ø30	ø12	M6		
* 10A(C)4,7X125	4,7	6,63	15,46	250	3500	46,1	96					
10A(C)5X125	5	7,05	14,10	250	3000	47,1	97,2					
10A(C)5,7X125	5,7	8,12	16,25	200	3000	48,5	100,1					
10A(C)6,1X125	6,1	8,69	14,49	200	2500	49,4	101,8					
10A(C)7,4X125	7,4	10,55	17,58	180	2500	52,1	107,2					
* 10A(C)8X125	8	11,40	15,20	150	2000	53,4	109,7					
10A(C)8,5X125	8,5	12,11	16,15	150	2000	54,4	111,7					
10A(C)9,8X125	9,8	13,97	18,62	120	2000	57	117					

* - These pumps - only under a special order

Rotation "A" - (anticlockwise)

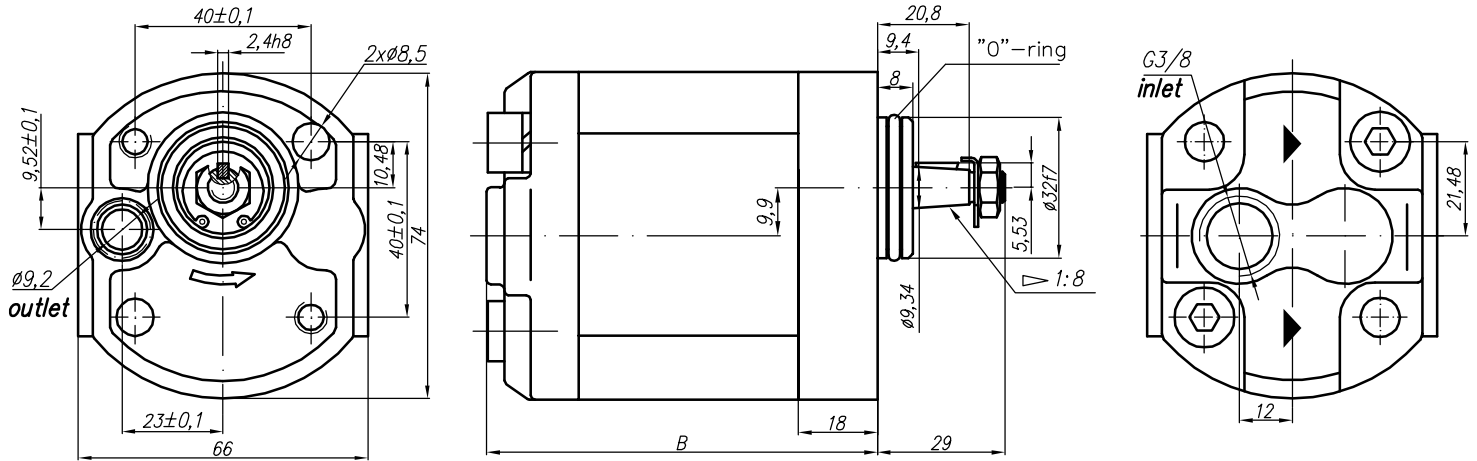

Rotation "C" - (clockwise)

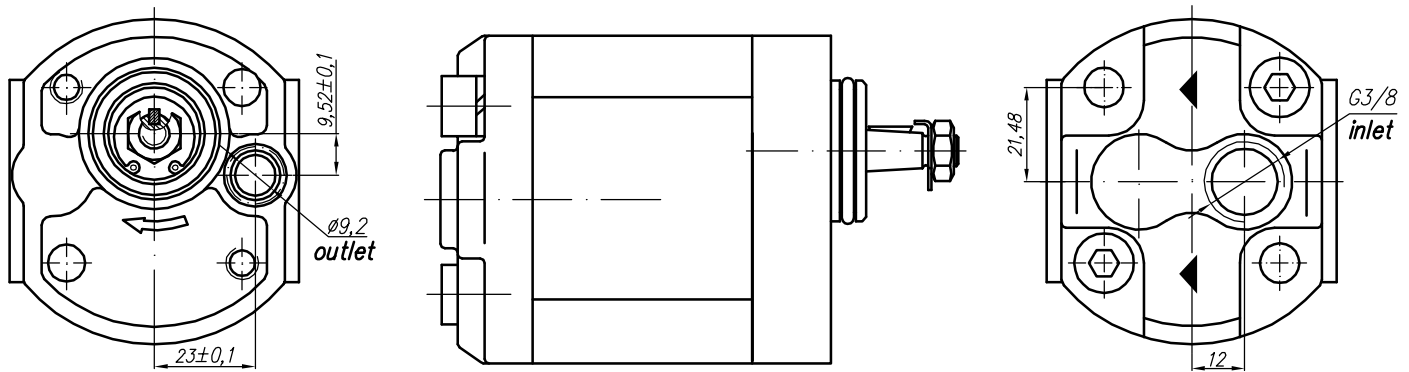

Type	Displacement cm ³ /rev	Flow		Pressure P _{nom} bar	max Speed n rpm	Dimension							
		at 1500 rpm l/min	at max rpm l/min			Inlet			Outlet				
						A mm	B mm	M	G	U	M	G	U
10A(C)1X131	1	1,40	3,26	250	3500	71	81	G 3/8" - A				Ø9,2	
10A(C)1,25X131	1,25	1,74	4,07	250	3500	72	82						
10A(C)1,6X131	1,6	2,23	5,21	250	3500	73,6	83,6						
10A(C)2X131	2	2,82	6,58	250	3500	75,2	85,2						
10A(C)2,5X131	2,5	3,53	8,23	250	3500	77,2	87,2						
* 10A(C)2,65X131	2,65	3,74	8,72	250	3500	77,8	87,8						
10A(C)3,15X131	3,15	4,44	10,36	250	3500	79,8	89,8						
10A(C)3,65X131	3,65	5,15	12,01	250	3500	81,9	91,9						
10A(C)4,2X131	4,2	5,92	13,82	250	3500	84,1	94,1						
* 10A(C)4,7X131	4,7	6,63	15,46	250	3500	87,1	97,1						
10A(C)5X131	5	7,05	14,10	250	3000	87,2	97,2						
10A(C)5,7X131	5,7	8,12	16,25	200	3000	90,1	100,1						
10A(C)6,1X131	6,1	8,69	14,49	200	2500	91,8	101,8						
10A(C)7,4X131	7,4	10,55	17,58	180	2500	97,2	107,2						
* 10A(C)8X131	8	11,40	15,20	150	2000	99,7	109,7						
10A(C)8,5X131	8,5	12,11	16,15	150	2000	101,7	111,7						
10A(C)9,8X131	9,8	13,97	18,62	120	2000	107	117						

* - These pumps - only under a special order

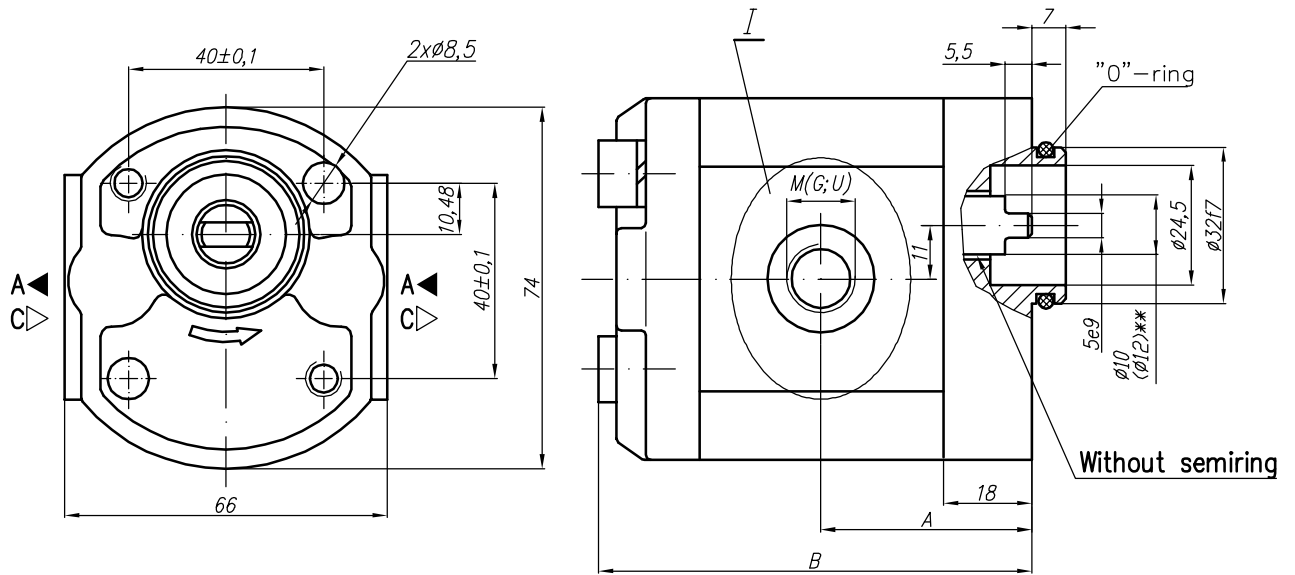

I - variants

Variants:

...X 135 M - for M ports (see the picture I and the table below);

...X 135 G - for G ports (see the picture I and the table below);

...X 135 U - for U ports (see the picture I and the table below).

Variant M

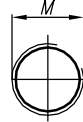

Variant G

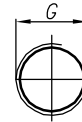

Variant U (SAEJ475 (ISO R725))

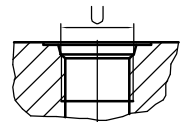

Type	Displacement cm ³ /rev	Flow		Pressure P _{nom} bar	max Speed n rpm	Dimension							
		at 1500 rpm l/min	at max rpm l/min			A mm	B mm	Inlet			Outlet		
								M	G	U	M	G	U
10A(C)1X135	1	1,40	3,26	250	3500	39,1	81	M16x1,5	G 3/8" - A	3/4" - 16UNF - 2B	M16x1,5	G 3/8" - A	9/16" - 18UNF - 2B
10A(C)1,25X135	1,25	1,74	4,07	250	3500	39,5	82						
10A(C)1,6X135	1,6	2,23	5,21	250	3500	40,3	83,6						
10A(C)2X135	2	2,82	6,58	250	3500	41,1	85,2						
10A(C)2,5X135	2,5	3,53	8,23	250	3500	42,1	87,2						
* 10A(C)2,65X135	2,65	3,74	8,72	250	3500	42,4	87,8	M20x1,5	G 1/2" - A	3/4" - 16UNF - 2B	M16x1,5	G 3/8" - A	9/16" - 18UNF - 2B
10A(C)3,15X135	3,15	4,44	10,36	250	3500	43,5	89,8						
10A(C)3,65X135	3,65	5,15	12,01	250	3500	44,4	91,9						
10A(C)4,2X135	4,2	5,92	13,82	250	3500	45,5	94,1						
* 10A(C)4,7X135	4,7	6,63	15,46	250	3500	46,1	96						
10A(C)5X135	5	7,05	14,10	250	3000	47,1	97,2	M22x1,5	7/8" - 14UNF	M18x1,5	G 3/8" - A	3/4" - 16UNF	
10A(C)5,7X135	5,7	8,12	16,25	200	3000	48,5	100,1						
10A(C)6,1X135	6,1	8,69	14,49	200	2500	49,4	101,8						
10A(C)7,4X135	7,4	10,55	17,58	180	2500	52,1	107,2						
* 10A(C)8X135	8	11,40	15,20	150	2000	53,4	109,7						
10A(C)8,5X135	8,5	12,11	16,15	150	2000	54,4	111,7						
10A(C)9,8X135	9,8	13,97	18,62	120	2000	57	117						

* - These pumps - only under a special order

** - Shaft dia is 10 mm for displ. 1 ... 6,1 ccm and 12 mm for displ. 7,4 ccm and more

The pump 10A(C)...X142 is a second section of multiple pump Gr.21.

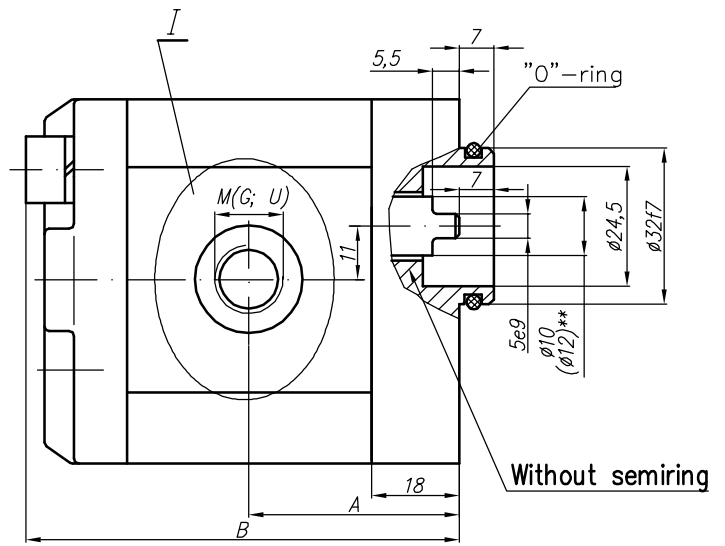
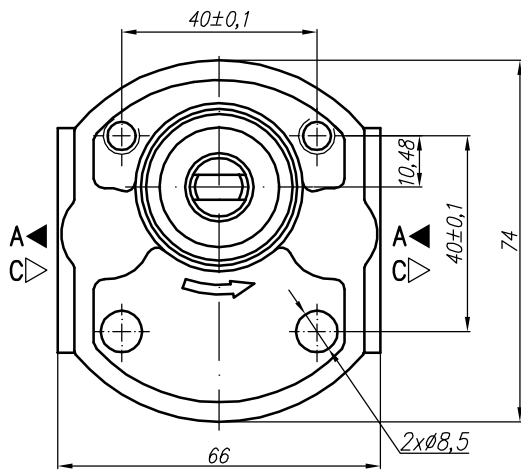

I - variants

Variants:

- ...X142M - for M ports (see the picture I and the table below);
- ...X142G - for G ports (see the picture I and the table below);
- ...X142U - for U ports (see the picture I and the table below).

Variant M



Variant G

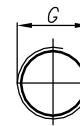

Variant U (SAEJ475 (ISO R725))

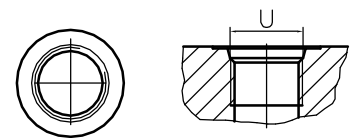

Type	Displacement cm ³ /rev	Flow		Pressure P _{nom} bar	max Speed n rpm	Dimension							
		at 1500 rpm l/min	at max rpm l/min			A mm	B mm	Inlet			Outlet		
								M	G	U	M	G	U
10A(C)1X142	1	1,40	3,26	250	3500	39,1	81	M16x1,5	G 3/8" - A	3/4" - 16UNF - 2B	M16x1,5	G 3/8" - A	9/16" - 18UNF - 2B
10A(C)1,25X142	1,25	1,74	4,07	250	3500	39,5	82						
10A(C)1,6X142	1,6	2,23	5,21	250	3500	40,3	83,6						
10A(C)2X142	2	2,82	6,58	250	3500	41,1	85,2						
10A(C)2,5X142	2,5	3,53	8,23	250	3500	42,1	87,2						
* 10A(C)2,65X142	2,65	3,74	8,72	250	3500	42,4	87,8	M20x1,5	G 1/2" - A	3/4" - 16UNF - 2B	M16x1,5	G 3/8" - A	9/16" - 18UNF - 2B
10A(C)3,15X142	3,15	4,44	10,36	250	3500	43,5	89,8						
10A(C)3,65X142	3,65	5,15	12,01	250	3500	44,4	91,9						
10A(C)4,2X142	4,2	5,92	13,82	250	3500	45,5	94,1	M22x1,5	G 1/2" - A	7/8" - 14UNF	M18x1,5	G 3/8" - A	3/4" - 16UNF
* 10A(C)4,7X142	4,7	6,63	15,46	250	3500	46,1	96						
10A(C)5X142	5	7,05	14,10	250	3000	47,1	97,2	M22x1,5	G 1/2" - A	7/8" - 14UNF	M18x1,5	G 3/8" - A	3/4" - 16UNF
10A(C)5,7X142	5,7	8,12	16,25	200	3000	48,5	100,1						
10A(C)6,1X142	6,1	8,69	14,49	200	2500	49,4	101,8	M22x1,5	G 1/2" - A	7/8" - 14UNF	M18x1,5	G 3/8" - A	3/4" - 16UNF
10A(C)7,4X142	7,4	10,55	17,58	180	2500	52,1	107,2						
* 10A(C)8X142	8	11,40	15,20	150	2000	53,4	109,7	M22x1,5	G 1/2" - A	7/8" - 14UNF	M18x1,5	G 3/8" - A	3/4" - 16UNF
10A(C)8,5X142	8,5	12,11	16,15	150	2000	54,4	111,7						
10A(C)9,8X142	9,8	13,97	18,62	120	2000	57	117	M22x1,5	G 1/2" - A	7/8" - 14UNF	M18x1,5	G 3/8" - A	3/4" - 16UNF

* - These pumps - only under a special order

** - Shaft dia is 10 mm for displ. 1 ... 6,1 ccm and 12 mm for displ. 7,4 ccm and more

The pump 10A(C)...X174 is a first section of multiple pump Gr.11.

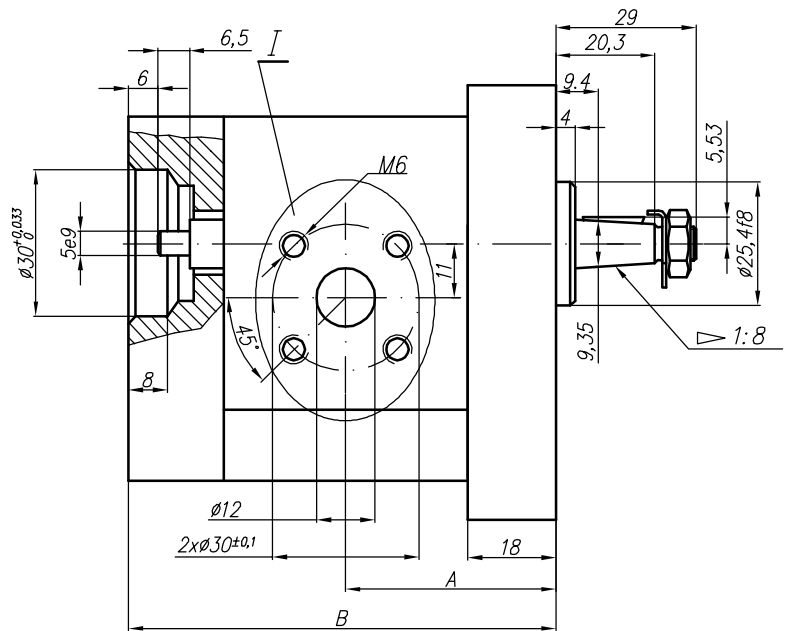
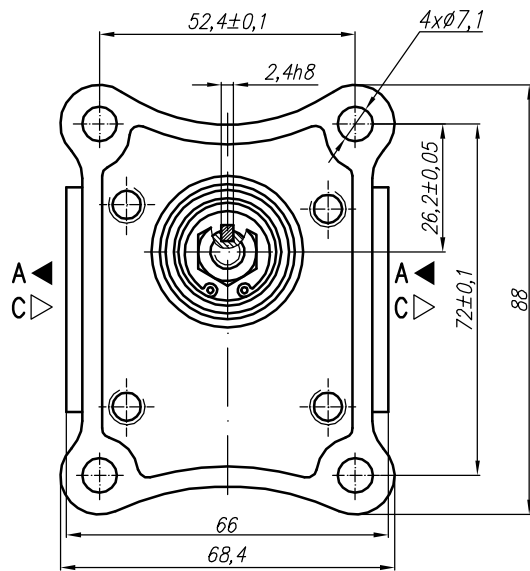

I – variants

Variants:

- ...X174 - Normal version (flange);
- ...X174M - for M ports (see the picture I and the table below);
- ...X174G - for G ports (see the picture I and the table below);
- ...X174U - for U ports (see the picture I and the table below).

Variant M



Variant G

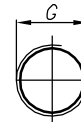

Variant U (SAEJ475 (ISO R725))

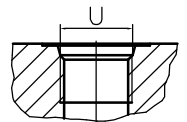
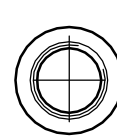

Type	Displacement cm ³ /rev	Flow		Pressure P _{nom} bar	max Speed n rpm	Dimension							
		at 1500 rpm l/min	at max rpm l/min			Inlet			Outlet				
						A mm	B mm	M	G	U	M	G	U
10A(C)1X174	1	1,40	3,26	250	3500	39,1	81	M16x1,5	G 3/8" - A	3/4" - 16UNF - 2B	M16x1,5	G 3/8" - A	9/16" - 18UNF - 2B
10A(C)1,25X174	1,25	1,74	4,07	250	3500	39,5	82						
10A(C)1,6X174	1,6	2,23	5,21	250	3500	40,3	83,6						
10A(C)2X174	2	2,82	6,58	250	3500	41,1	85,2						
10A(C)2,5X174	2,5	3,53	8,23	250	3500	42,1	87,2	M20x1,5	G 1/2" - A	3/4" - 16UNF - 2B	M16x1,5	G 3/8" - A	9/16" - 18UNF - 2B
* 10A(C)2,65X174	2,65	3,74	8,72	250	3500	42,4	87,8						
10A(C)3,15X174	3,15	4,44	10,36	250	3500	43,5	89,8	M20x1,5	G 1/2" - A	3/4" - 16UNF - 2B	M16x1,5	G 3/8" - A	9/16" - 18UNF - 2B
10A(C)3,65X174	3,65	5,15	12,01	250	3500	44,4	91,9						
10A(C)4,2X174	4,2	5,92	13,82	250	3500	45,5	94,1	M20x1,5	G 1/2" - A	3/4" - 16UNF - 2B	M16x1,5	G 3/8" - A	9/16" - 18UNF - 2B
* 10A(C)4,7X174	4,7	6,63	15,46	250	3500	46,1	96						
10A(C)5X174	5	7,05	14,10	250	3000	47,1	97,2	M22x1,5	G 1/2" - A	7/8" - 14UNF	M18x1,5	G 3/8" - A	3/4" - 16UNF
10A(C)5,7X174	5,7	8,12	16,25	200	3000	48,5	100,1						
10A(C)6,1X174	6,1	8,69	14,49	200	2500	49,4	101,8	M22x1,5	G 1/2" - A	7/8" - 14UNF	M18x1,5	G 3/8" - A	3/4" - 16UNF
10A(C)7,4X174	7,4	10,55	17,58	180	2500	52,1	107,2						
* 10A(C)8X174	8	11,40	15,20	150	2000	53,4	109,7	M22x1,5	G 1/2" - A	7/8" - 14UNF	M18x1,5	G 3/8" - A	3/4" - 16UNF
10A(C)8,5X174	8,5	12,11	16,15	150	2000	54,4	111,7						
10A(C)9,8X174	9,8	13,97	18,62	120	2000	57	117	M22x1,5	G 1/2" - A	7/8" - 14UNF	M18x1,5	G 3/8" - A	3/4" - 16UNF

* - These pumps - only under a special order

The pump 10A(C)...X175 is a second section of multiple pump Gr.11.

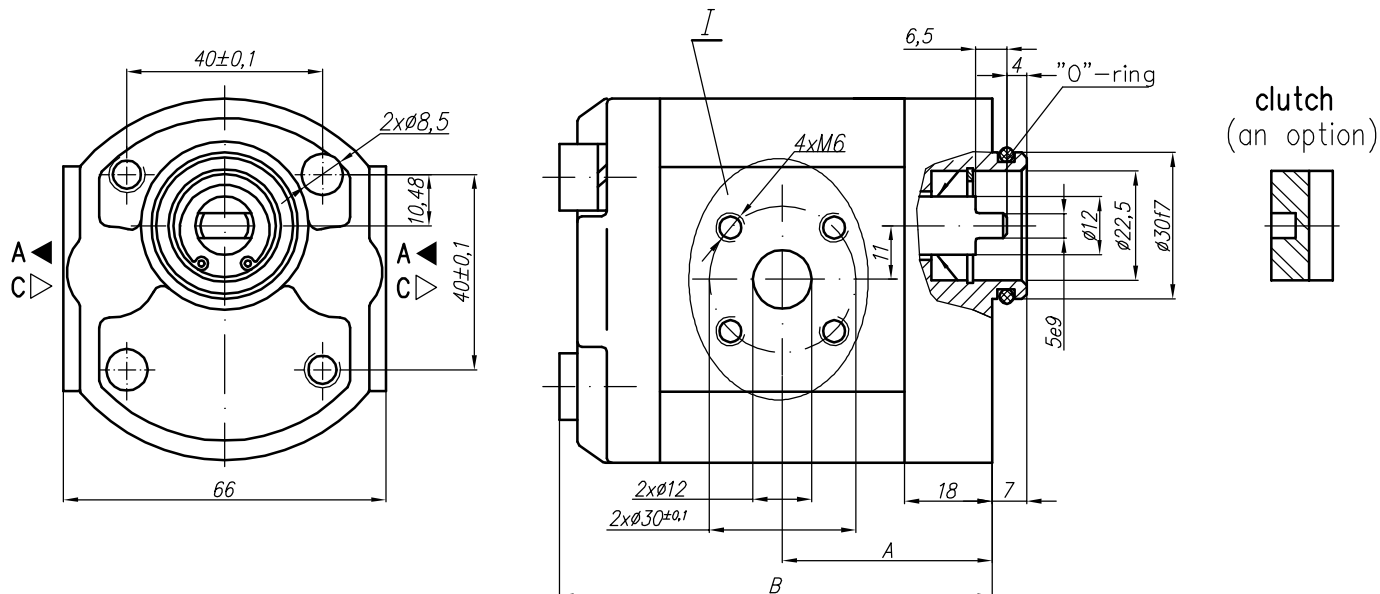

Variants:

- ...X175 - Normal version (flange);
- ...X175M - for M ports (see the picture I and the table below);
- ...X175G - for G ports (see the picture I and the table below);
- ...X175U - for U ports (see the picture I and the table below).

I - variants

Variant M

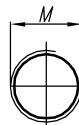

Variant G

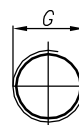

Variant U (SAEJ475 (ISO R725))

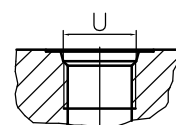

Type	Displacement cm ³ /rev	Flow		Pressure P _{nom} bar	max Speed n rpm	Dimension							
		at 1500 rpm l/min	at max rpm l/min			A mm	B mm	Inlet			Outlet		
								M	G	U	M	G	U
10A(C)1X175	1	1,40	3,26	250	3500	39,1	81	M16x1,5	G 3/8" - A	3/4" - 16UNF - 2B	M16x1,5	G 3/8" - A	9/16" - 18UNF - 2B
10A(C)1,25X175	1,25	1,74	4,07	250	3500	39,5	82						
10A(C)1,6X175	1,6	2,23	5,21	250	3500	40,3	83,6						
10A(C)2X175	2	2,82	6,58	250	3500	41,1	85,2						
10A(C)2,5X175	2,5	3,53	8,23	250	3500	42,1	87,2						
* 10A(C)2,65X175	2,65	3,74	8,72	250	3500	42,4	87,8	M20x1,5	G 1/2" - A	3/4" - 16UNF - 2B	M16x1,5	G 3/8" - A	9/16" - 18UNF - 2B
10A(C)3,15X175	3,15	4,44	10,36	250	3500	43,5	89,8						
10A(C)3,65X175	3,65	5,15	12,01	250	3500	44,4	91,9						
10A(C)4,2X175	4,2	5,92	13,82	250	3500	45,5	94,1						
* 10A(C)4,7X175	4,7	6,63	15,46	250	3500	46,1	96						
10A(C)5X175	5	7,05	14,10	250	3000	47,1	97,2	M22x1,5	G 1/2" - A	7/8" - 14UNF	M18x1,5	G 3/8" - A	3/4" - 16UNF
10A(C)5,7X175	5,7	8,12	16,25	200	3000	48,5	100,1						
10A(C)6,1X175	6,1	8,69	14,49	200	2500	49,4	101,8						
10A(C)7,4X175	7,4	10,55	17,58	180	2500	52,1	107,2						
* 10A(C)8X175	8	11,40	15,20	150	2000	53,4	109,7						
10A(C)8,5X175	8,5	12,11	16,15	150	2000	54,4	111,7	M22x1,5	G 1/2" - A	7/8" - 14UNF	M18x1,5	G 3/8" - A	3/4" - 16UNF
10A(C)9,8X175	9,8	13,97	18,62	120	2000	57	117						

* - These pumps - only under a special order

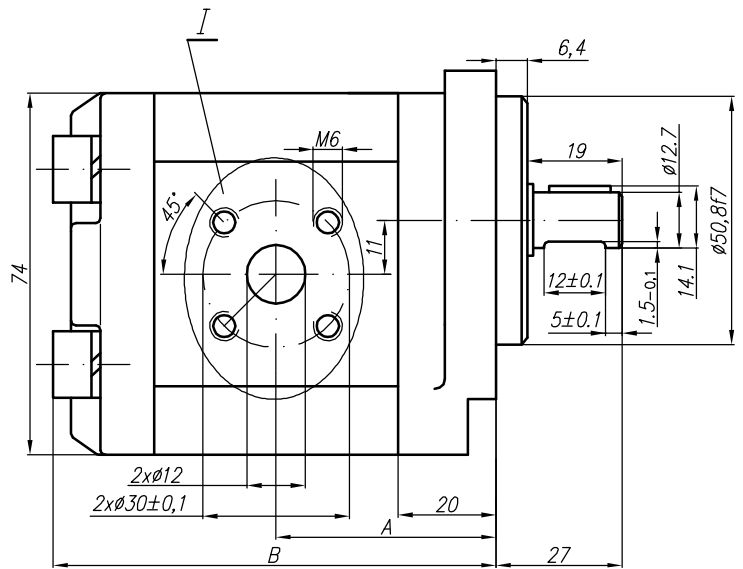
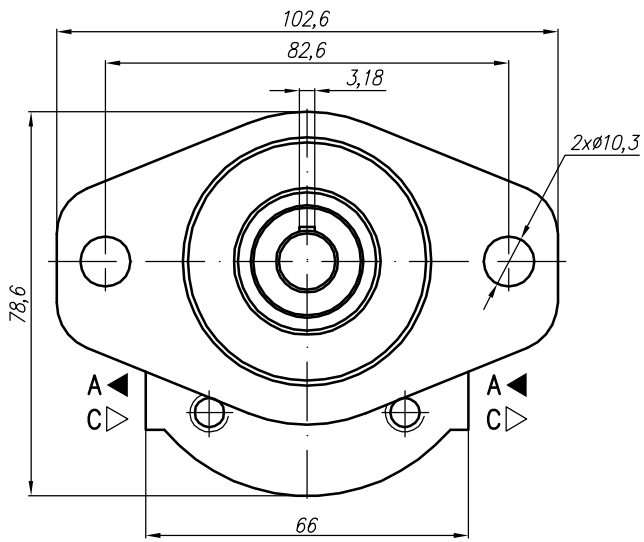

I - variants

Variants:

- ...X176 - Normal version (flange);
- ...X176M - for M ports (see the picture I and the table below);
- ...X176G - for G ports (see the picture I and the table below);
- ...X176U - for U ports (see the picture I and the table below).

Variant M



Variant G

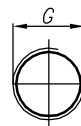

Variant U (SAEJ475 (ISO R725))

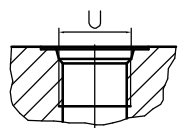

Type	Displacement cm ³ /rev	Flow		Pressure P _{nom} bar	max Speed n rpm	Dimension							
		at 1500 rpm l/min	at max rpm l/min			A mm	B mm	Inlet			Outlet		
								M	G	U	M	G	U
10A(C)1X176	1	1,40	3,26	250	3500	41,1	83	M16x1,5	G 3/8" - A	3/4" - 16UNF - 2B	M16x1,5	G 3/8" - A	9/16" - 18UNF - 2B
10A(C)1,25X176	1,25	1,74	4,07	250	3500	41,5	84						
10A(C)1,6X176	1,6	2,23	5,21	250	3500	42,3	85,6						
10A(C)2X176	2	2,82	6,58	250	3500	43,1	87,2						
10A(C)2,5X176	2,5	3,53	8,23	250	3500	44,1	89,2	M20x1,5	G 1/2" - A	3/4" - 16UNF - 2B	M16x1,5	G 3/8" - A	9/16" - 18UNF - 2B
* 10A(C)2,65X176	2,65	3,74	8,72	250	3500	44,4	89,8						
10A(C)3,15X176	3,15	4,44	10,36	250	3500	45,5	91,8	M20x1,5	G 1/2" - A	3/4" - 16UNF - 2B	M16x1,5	G 3/8" - A	9/16" - 18UNF - 2B
10A(C)3,65X176	3,65	5,15	12,01	250	3500	46,4	93,9						
10A(C)4,2X176	4,2	5,92	13,82	250	3500	47,5	96,1	M22x1,5	G 1/2" - A	3/4" - 16UNF - 2B	M18x1,5	G 3/8" - A	9/16" - 18UNF - 2B
* 10A(C)4,7X176	4,7	6,63	15,46	250	3500	48,5	98						
10A(C)5X176	5	7,05	14,10	250	3000	49,1	99,2	M22x1,5	G 1/2" - A	7/8" - 14UNF	M18x1,5	G 3/8" - A	3/4" - 16UNF
10A(C)5,7X176	5,7	8,12	16,25	200	3000	50,5	102						
10A(C)6,1X176	6,1	8,69	14,49	200	2500	51,4	103,8	M22x1,5	G 1/2" - A	7/8" - 14UNF	M18x1,5	G 3/8" - A	3/4" - 16UNF
10A(C)7,4X176	7,4	10,55	17,58	180	2500	54,1	109,2						
* 10A(C)8X176	8	11,40	15,20	150	2000	55,4	111,7	M22x1,5	G 1/2" - A	7/8" - 14UNF	M18x1,5	G 3/8" - A	3/4" - 16UNF
10A(C)8,5X176	8,5	12,11	16,15	150	2000	56,4	113,7						
10A(C)9,8X176	9,8	13,97	18,62	120	2000	59	119	M22x1,5	G 1/2" - A	7/8" - 14UNF	M18x1,5	G 3/8" - A	3/4" - 16UNF

* - These pumps - only under a special order

the pump 10A(C)...X179 is a second section of multiple pump Gr.21.

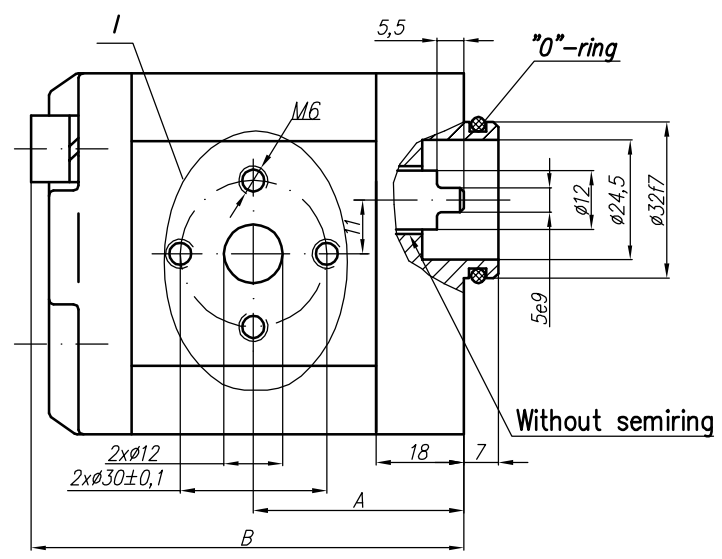
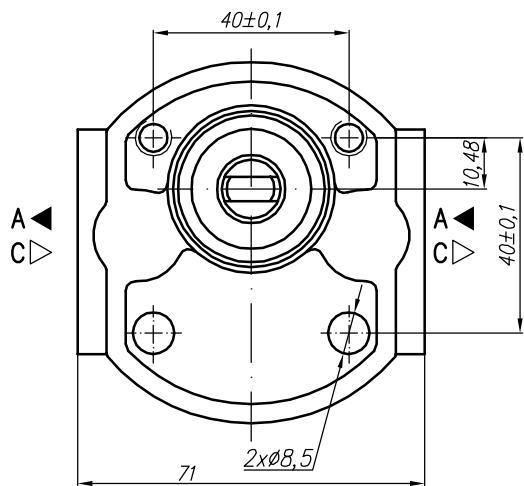

Variants:

- ...X179 - Normal version (flange);
- ...X179E - "Italy" ports (see the picture I and the table below)
- ...X179M - for M ports (see the picture I and the table below);
- ...X179G - for G ports (see the picture I and the table below);
- ...X179U - for U ports (see the picture I and the table below).

I - variants

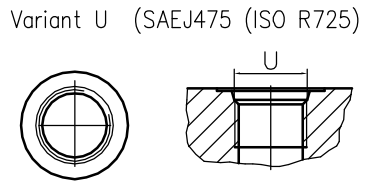
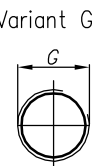
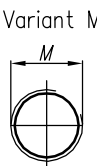
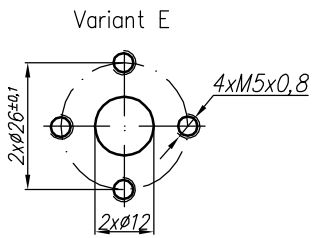

Type	Displacement cm ³ /rev	Flow		Pressure P _{nom} bar	max Speed n rpm	Dimension							
		at 1500 rpm l/min	at max rpm l/min			Inlet			Outlet				
						A mm	B mm	M	G	U	M	G	U
10A(C)1X179	1	1,40	3,26	250	3500	39,1	81	M16x1,5	G 3/8" - A	3/4" - 16UNF - 2B	M16x1,5	G 3/8" - A	9/16" - 18UNF - 2B
10A(C)1,25X179	1,25	1,74	4,07	250	3500	39,5	82						
10A(C)1,6X179	1,6	2,23	5,21	250	3500	40,3	83,6						
10A(C)2X179	2	2,82	6,58	250	3500	41,1	85,2						
10A(C)2,5X179	2,5	3,53	8,23	250	3500	42,1	87,2	M20x1,5	G 1/2" - A	3/4" - 16UNF - 2B	M16x1,5	G 3/8" - A	9/16" - 18UNF - 2B
* 10A(C)2,65X179	2,65	3,74	8,72	250	3500	42,4	87,8						
10A(C)3,15X179	3,15	4,44	10,36	250	3500	43,5	89,8	M22x1,5	G 1/2" - A	7/8" - 14UNF	M18x1,5	G 3/8" - A	3/4" - 16UNF
10A(C)3,65X179	3,65	5,15	12,01	250	3500	44,4	91,9						
10A(C)4,2X179	4,2	5,92	13,82	250	3500	45,5	94,1	M22x1,5	G 1/2" - A	7/8" - 14UNF	M18x1,5	G 3/8" - A	3/4" - 16UNF
* 10A(C)4,7X179	4,7	6,63	15,46	250	3500	46,1	96						
10A(C)5X179	5	7,05	14,10	250	3000	47,1	97,2	M22x1,5	G 1/2" - A	7/8" - 14UNF	M18x1,5	G 3/8" - A	3/4" - 16UNF
10A(C)5,7X179	5,7	8,12	16,25	200	3000	48,5	100,1						
10A(C)6,1X179	6,1	8,69	14,49	200	2500	49,4	101,8	M22x1,5	G 1/2" - A	7/8" - 14UNF	M18x1,5	G 3/8" - A	3/4" - 16UNF
10A(C)7,4X179	7,4	10,55	17,58	180	2500	52,1	107,2						
* 10A(C)8X179	8	11,40	15,20	150	2000	53,4	109,7	M22x1,5	G 1/2" - A	7/8" - 14UNF	M18x1,5	G 3/8" - A	3/4" - 16UNF
10A(C)8,5X179	8,5	12,11	16,15	150	2000	54,4	111,7						
10A(C)9,8X179	9,8	13,97	18,62	120	2000	57	117	M22x1,5	G 1/2" - A	7/8" - 14UNF	M18x1,5	G 3/8" - A	3/4" - 16UNF

* - These pumps - only under a special order

The pump 10A(C)...X182 is a second section of a multiple pump Gr.11.

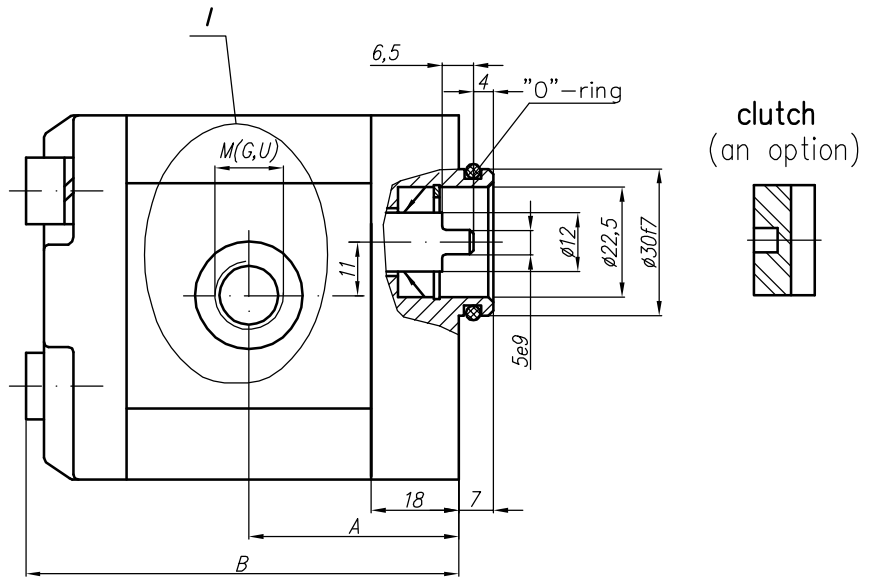
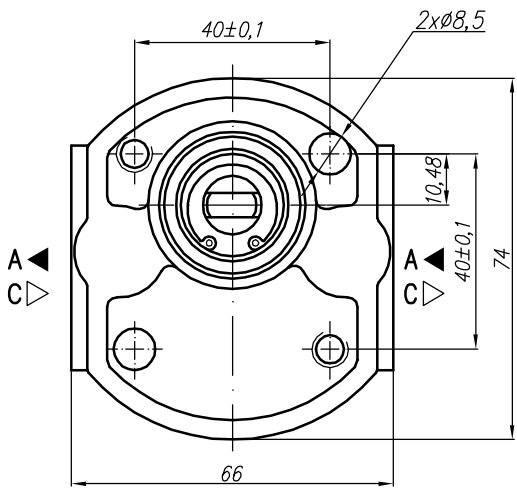

Variants:

- ...X182M - for M ports (see the picture I and the table below);
- ...X182G - for G ports (see the picture I and the table below);
- ...X182U - for U ports (see the picture I and the table below).

I - variants

Variant M

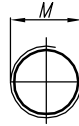

Variant G



Variant U (SAEJ475 (ISO R725))

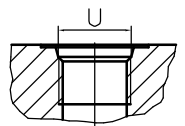

Type	Displacement cm ³ /rev	Flow		Pressure P _{nom} bar	max Speed n rpm	Dimension							
		at 1500 rpm l/min	at max rpm l/min			A mm	B mm	Inlet			Outlet		
								M	G	U	M	G	U
10A(C)1X182	1	1,40	3,26	250	3500	39,1	81	M16x1,5	G 3/8" - A	3/4" - 16UNF - 2B	M16x1,5	G 3/8" - A	9/16" - 18UNF - 2B
10A(C)1,25X182	1,25	1,74	4,07	250	3500	39,5	82						
10A(C)1,6X182	1,6	2,23	5,21	250	3500	40,3	83,6						
10A(C)2X182	2	2,82	6,58	250	3500	41,1	85,2						
10A(C)2,5X182	2,5	3,53	8,23	250	3500	42,1	87,2						
* 10A(C)2,65X182	2,65	3,74	8,72	250	3500	42,4	87,8	M20x1,5	G 1/2" - A	3/4" - 16UNF - 2B	M16x1,5	G 3/8" - A	9/16" - 18UNF - 2B
10A(C)3,15X182	3,15	4,44	10,36	250	3500	43,5	89,8						
10A(C)3,65X182	3,65	5,15	12,01	250	3500	44,4	91,9						
10A(C)4,2X182	4,2	5,92	13,82	250	3500	45,5	94,1						
* 10A(C)4,7X182	4,7	6,63	15,46	250	3500	46,1	96						
10A(C)5X182	5	7,05	14,10	250	3000	47,1	97,2	M22x1,5	G 1/2" - A	7/8" - 14UNF	M18x1,5	G 3/8" - A	3/4" - 16UNF
10A(C)5,7X182	5,7	8,12	16,25	200	3000	48,5	100,1						
10A(C)6,1X182	6,1	8,69	14,49	200	2500	49,4	101,8						
10A(C)7,4X182	7,4	10,55	17,58	180	2500	52,1	107,2						
* 10A(C)8X182	8	11,40	15,20	150	2000	53,4	109,7						
10A(C)8,5X182	8,5	12,11	16,15	150	2000	54,4	111,7	M22x1,5	G 1/2" - A	7/8" - 14UNF	M18x1,5	G 3/8" - A	3/4" - 16UNF
10A(C)9,8X182	9,8	13,97	18,62	120	2000	57	117						

* - These pumps - only under a special order

the pump 10A(C)...X230 is a first section of a series of pumps for mini power packs.

Rotation "A" - (anticlockwise)

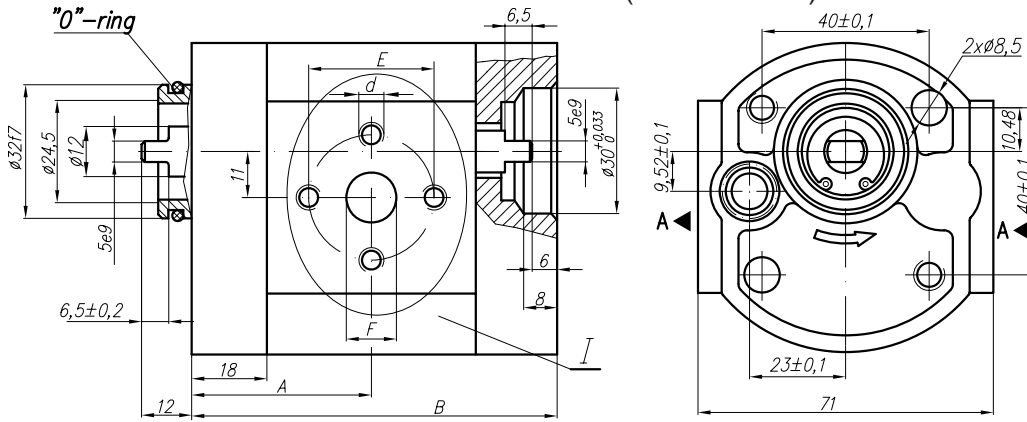

Rotation "C" - (clockwise)

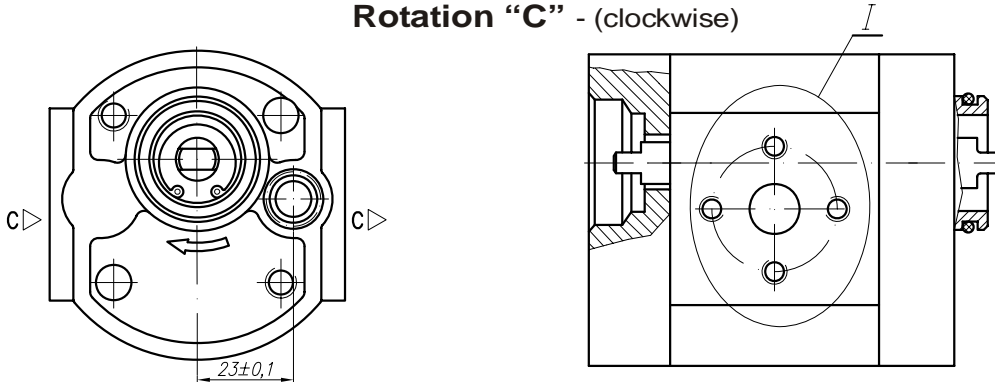

I - variants

Variants:

- ...X230 - Normal version (flange);
- ...X230M - for M ports (see the picture I and the table below);
- ...X230G - for G ports (see the picture I and the table below);
- ...X230U - for U ports (see the picture I and the table below).

Variant M

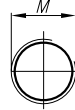

Variant G

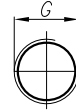

Variant U (SAEJ475 (ISO R725))

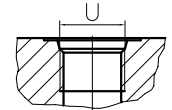

Type	Displacement cm ³ /rev	Flow		Pressure P _{nom} bar	max Speed n rpm	Dimension							
		at 1500 rpm l/min	at max rpm l/min			A mm	B mm	Inlet					
						E	F	d	M	G	U		
10A(C)1X230	1	1,40	3,26	250	3500	39,1	79						
10A(C)1,25X230	1,25	1,74	4,07	250	3500	39,5	80						
10A(C)1,6X230	1,6	2,23	5,21	250	3500	40,3	81,6						
10A(C)2X230	2	2,82	6,58	250	3500	41,1	83,2						
10A(C)2,5X230	2,5	3,53	8,23	250	3500	42,1	85,2						
* 10A(C)2,65X230	2,65	3,74	8,72	250	3500	42,4	85,8						
10A(C)3,15X230	3,15	4,44	10,36	250	3500	43,5	87,8						
10A(C)3,65X230	3,65	5,15	12,01	250	3500	44,4	89,9						
10A(C)4,2X230	4,2	5,92	13,82	250	3500	45,5	92,1	∅30	∅12	M6			
* 10A(C)4,7X230	4,7	6,63	15,46	250	3500	46,1	94						
10A(C)5X230	5	7,05	14,10	250	3000	47,1	95,2						
10A(C)5,7X230	5,7	8,12	16,25	200	3000	48,5	98,1						
10A(C)6,1X230	6,1	8,69	14,49	200	2500	49,4	99,8						
10A(C)7,4X230	7,4	10,55	17,58	180	2500	52,1	105,2						
* 10A(C)8X230	8	11,40	15,20	150	2000	53,4	107,7						
10A(C)8,5X230	8,5	12,11	16,15	150	2000	54,4	109,7						
10A(C)9,8X230	9,8	13,97	18,62	120	2000	57	115						

* - These pumps - only under a special order

The pump 10A(C)...X231 is a second section of a multiple pump Gr.11.

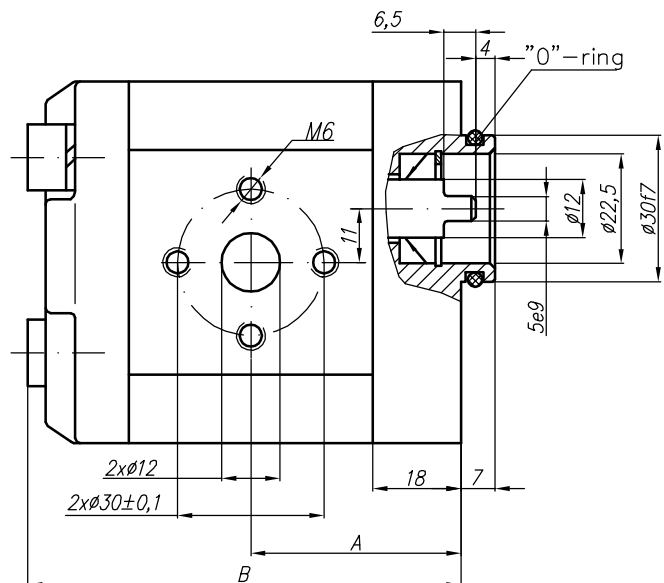
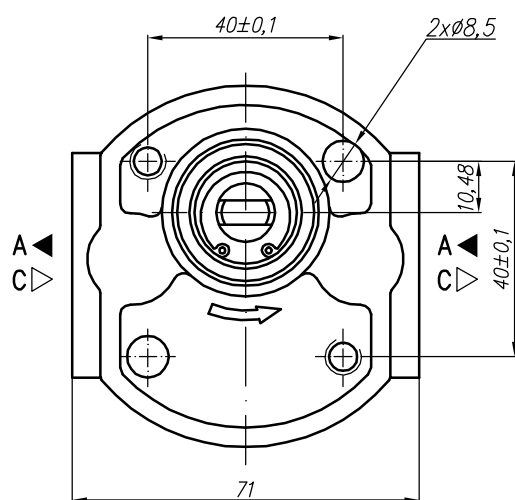

Type	Displacement cm ³ /rev	Flow		Pressure P _{nom} bar	max Speed n rpm	Dimension							
		at 1500 rpm l/min	at max rpm l/min			Inlet			Outlet				
						A mm	B mm	E	F	d	E	F	d
10A(C)1X231	1	1,40	3,26	250	3500	39,1	79						
10A(C)1,25X231	1,25	1,74	4,07	250	3500	39,5	80						
10A(C)1,6X231	1,6	2,23	5,21	250	3500	40,3	81,6						
10A(C)2X231	2	2,82	6,58	250	3500	41,1	83,2						
10A(C)2,5X231	2,5	3,53	8,23	250	3500	42,1	85,2						
* 10A(C)2,65X231	2,65	3,74	8,72	250	3500	42,4	85,8						
10A(C)3,15X231	3,15	4,44	10,36	250	3500	43,5	87,8						
10A(C)3,65X231	3,65	5,15	12,01	250	3500	44,4	89,9						
10A(C)4,2X231	4,2	5,92	13,82	250	3500	45,5	92,1	Ø30	Ø12	M6	Ø30	Ø12	M6
* 10A(C)4,7X231	4,7	6,63	15,46	250	3500	46,1	94						
10A(C)5X231	5	7,05	14,10	250	3000	47,1	95,2						
10A(C)5,7X231	5,7	8,12	16,25	200	3000	48,5	98,1						
10A(C)6,1X231	6,1	8,69	14,49	200	2500	49,4	99,8						
10A(C)7,4X231	7,4	10,55	17,58	180	2500	52,1	105,2						
* 10A(C)8X231	8	11,40	15,20	150	2000	53,4	107,7						
10A(C)8,5X231	8,5	12,11	16,15	150	2000	54,4	109,7						
10A(C)9,8X231	9,8	13,97	18,62	120	2000	57	115						

* - These pumps - only under a special order

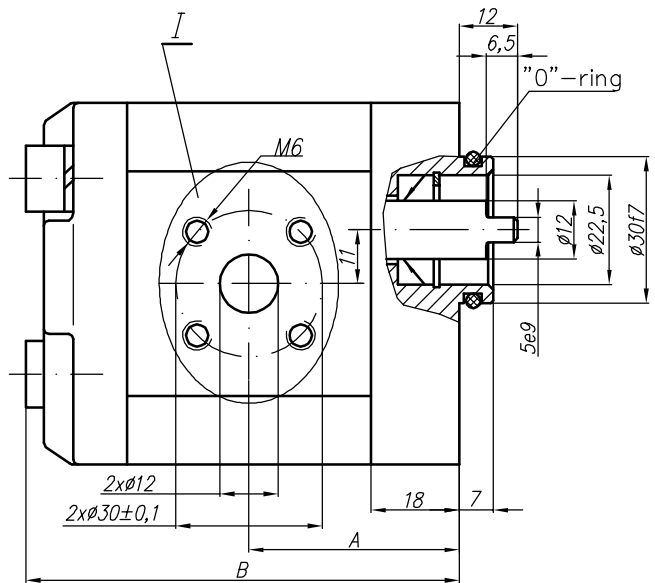
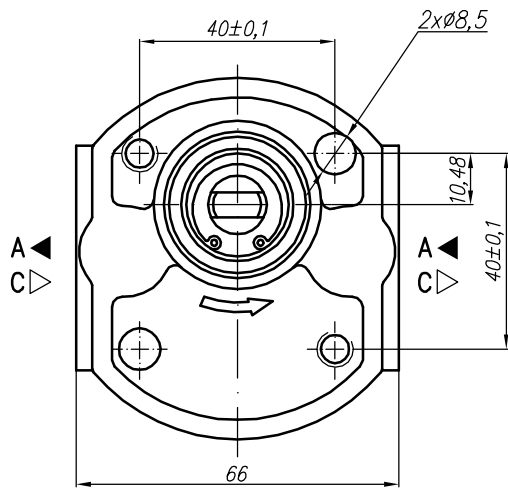

I – variants

Variants:

- ...X238 - Normal version (flange);
- ...X238M - for M ports (see the picture I and the table below);
- ...X238G - for G ports (see the picture I and the table below);
- ...X238U - for U ports (see the picture I and the table below).

Variant M



Variant G

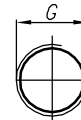

Variant U (SAEJ475 (ISO R725))

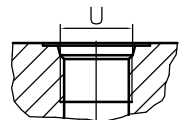

Type	Displacement cm ³ /rev	Flow		Pressure P _{nom} bar	max Speed n rpm	Dimension							
		at 1500 rpm l/min	at max rpm l/min			Inlet			Outlet				
						A mm	B mm	M	G	U	M	G	U
10A(C)1X238	1	1,40	3,26	250	3500	39,1	81	M16x1,5	G 3/8" - A	3/4" - 16UNF - 2B	M16x1,5	G 3/8" - A	9/16" - 18UNF - 2B
10A(C)1,25X238	1,25	1,74	4,07	250	3500	39,5	82						
10A(C)1,6X238	1,6	2,23	5,21	250	3500	40,3	83,6						
10A(C)2X238	2	2,82	6,58	250	3500	41,1	85,2						
10A(C)2,5X238	2,5	3,53	8,23	250	3500	42,1	87,2						
* 10A(C)2,65X238	2,65	3,74	8,72	250	3500	42,4	87,8	M20x1,5	G 1/2" - A	3/4" - 16UNF - 2B	M16x1,5	G 3/8" - A	9/16" - 18UNF - 2B
10A(C)3,15X238	3,15	4,44	10,36	250	3500	43,5	89,8						
10A(C)3,65X238	3,65	5,15	12,01	250	3500	44,4	91,9	M22x1,5	G 1/2" - A	7/8" - 14UNF	M18x1,5	G 3/8" - A	3/4" - 16UNF
10A(C)4,2X238	4,2	5,92	13,82	250	3500	45,5	94,1						
* 10A(C)4,7X238	4,7	6,63	15,46	250	3500	46,1	96						
10A(C)5X238	5	7,05	14,10	250	3000	47,1	97,2	M22x1,5	G 1/2" - A	7/8" - 14UNF	M18x1,5	G 3/8" - A	3/4" - 16UNF
10A(C)5,7X238	5,7	8,12	16,25	200	3000	48,5	100,1						
10A(C)6,1X238	6,1	8,69	14,49	200	2500	49,4	101,8						
10A(C)7,4X238	7,4	10,55	17,58	180	2500	52,1	107,2	M22x1,5	G 1/2" - A	7/8" - 14UNF	M18x1,5	G 3/8" - A	3/4" - 16UNF
* 10A(C)8X238	8	11,40	15,20	150	2000	53,4	109,7						
10A(C)8,5X238	8,5	12,11	16,15	150	2000	54,4	111,7						
10A(C)9,8X238	9,8	13,97	18,62	120	2000	57	117	M22x1,5	G 1/2" - A	7/8" - 14UNF	M18x1,5	G 3/8" - A	3/4" - 16UNF

* - These pumps - only under a special order

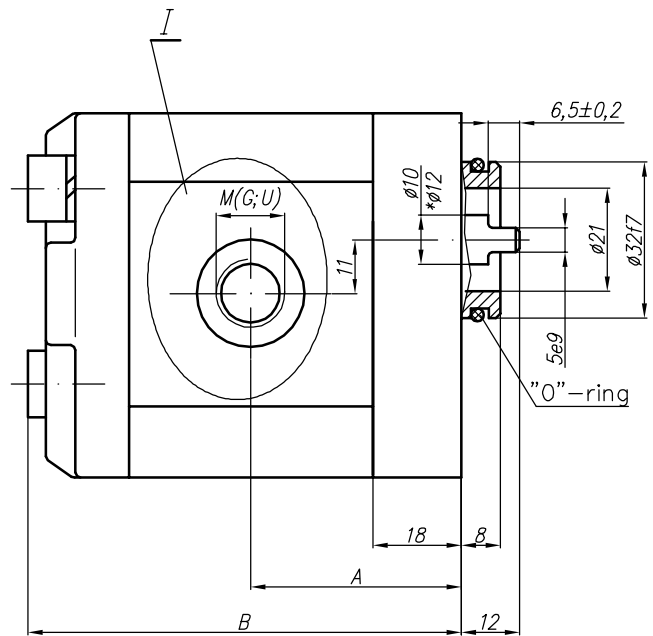
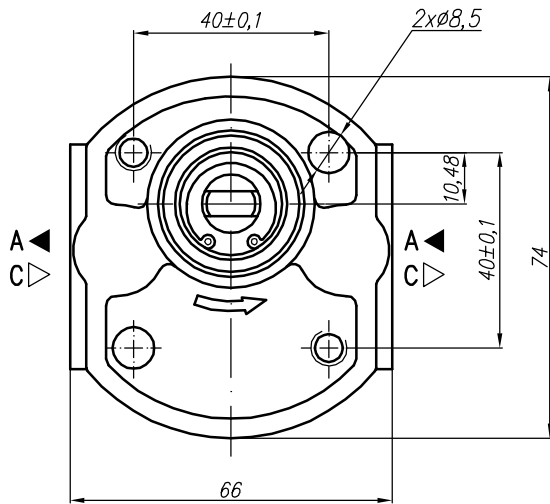

I – variants

Variants:

...X244M - for M ports (see the picture I and the table below);

...X244G - for G ports (see the picture I and the table below);

...X244U - for U ports (see the picture I and the table below).

Variant M



Variant G

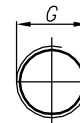

Variant U (SAEJ475 (ISO R725))

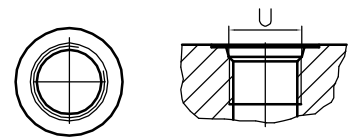

Type	Displacement cm ³ /rev	Flow		Pressure P _{nom} bar	max Speed n rpm	Dimension							
		at 1500 rpm l/min	at max rpm l/min			A mm	B mm	Inlet			Outlet		
								M	G	U	M	G	U
10A(C)1X244	1	1,40	3,26	250	3500	39,1	81	M16x1,5	G 3/8" - A	3/4" - 16UNF - 2B	M16x1,5	G 3/8" - A	9/16" - 18UNF - 2B
10A(C)1,25X244	1,25	1,74	4,07	250	3500	39,5	82						
10A(C)1,6X244	1,6	2,23	5,21	250	3500	40,3	83,6						
10A(C)2X244	2	2,82	6,58	250	3500	41,1	85,2						
10A(C)2,5X244	2,5	3,53	8,23	250	3500	42,1	87,2						
* 10A(C)2,65X244	2,65	3,74	8,72	250	3500	42,4	87,8	M20x1,5	G 1/2" - A	3/4" - 16UNF - 2B	M16x1,5	G 3/8" - A	9/16" - 18UNF - 2B
10A(C)3,15X244	3,15	4,44	10,36	250	3500	43,5	89,8						
10A(C)3,65X244	3,65	5,15	12,01	250	3500	44,4	91,9						
10A(C)4,2X244	4,2	5,92	13,82	250	3500	45,5	94,1						
* 10A(C)4,7X244	4,7	6,63	15,46	250	3500	46,1	96						
10A(C)5X244	5	7,05	14,10	250	3000	47,1	97,2	M22x1,5	7/8" - 14UNF	M18x1,5	G 3/8" - A	3/4" - 16UNF	
10A(C)5,7X244	5,7	8,12	16,25	200	3000	48,5	100,1						
10A(C)6,1X244	6,1	8,69	14,49	200	2500	49,4	101,8						
10A(C)7,4X244	7,4	10,55	17,58	180	2500	52,1	107,2						
* 10A(C)8X244	8	11,40	15,20	150	2000	53,4	109,7						
10A(C)8,5X244	8,5	12,11	16,15	150	2000	54,4	111,7	M22x1,5	7/8" - 14UNF	M18x1,5	G 3/8" - A	3/4" - 16UNF	
10A(C)9,8X244	9,8	13,97	18,62	120	2000	57	117						

* - These pumps - only under a special order

** - Shaft dia is 10 mm for displ. 1 ... 6,1 ccm and 12 mm for displ. 7,4 ccm and more

Rotation "A" - (anticlockwise)

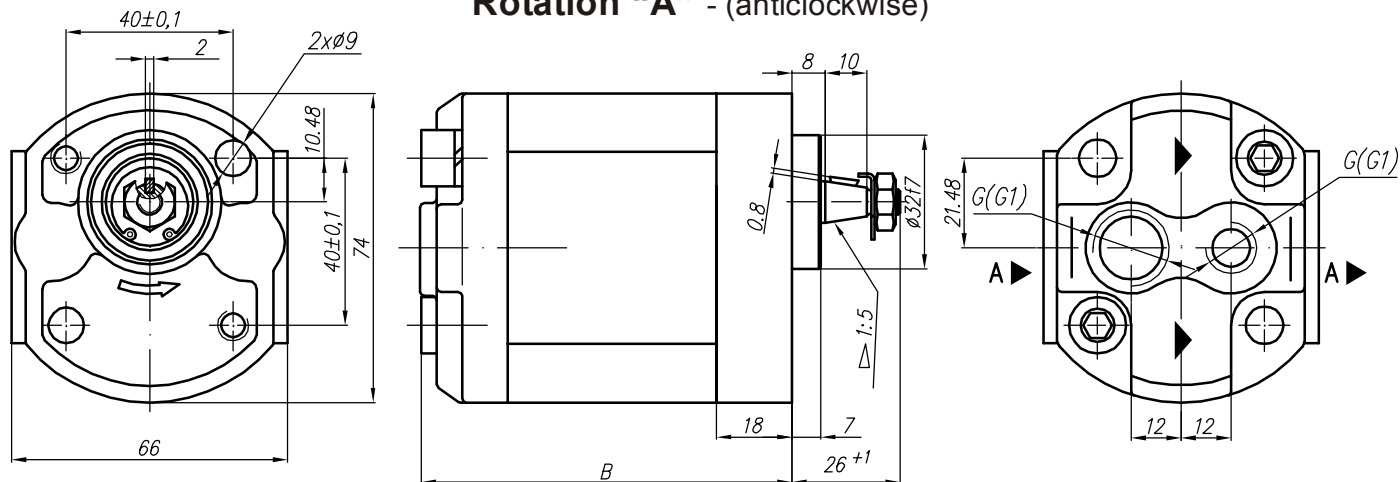

Rotation "C" - (clockwise)

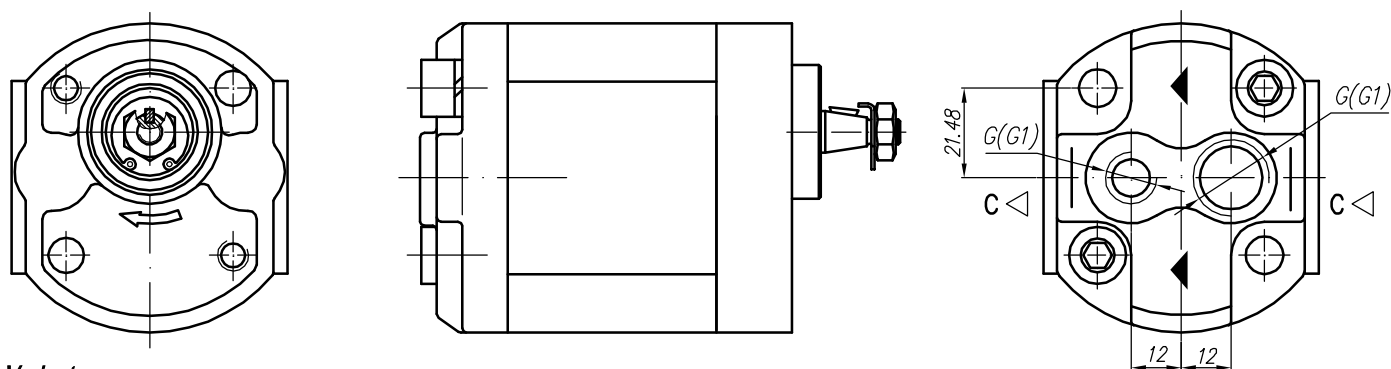

Variants:

- ...X254G - for G ports (see the picture and the table);
- ...X254G1 - for G1 ports (see the picture and the table).

Type	Displacement cm ³ /rev	Flow		Pressure P _{nom} bar	max Speed n rpm	Dimension					
		at 1500 rpm l/min	at max rpm l/min			A mm	B mm	Inlet		Outlet	
								G	G ₁	G	G ₁
10A(C)1X254	1	1,40	3,26	250	3500	71	81	G 1/4" - A	G 3/8" - A	G 1/4" - A	G 1/4" - A
10A(C)1,25X254	1,25	1,74	4,07	250	3500	72	82				
10A(C)1,6X254	1,6	2,23	5,21	250	3500	73,6	83,6				
10A(C)2X254	2	2,82	6,58	250	3500	75,2	85,2				
10A(C)2,5X254	2,5	3,53	8,23	250	3500	77,2	87,2				
* 10A(C)2,65X254	2,65	3,74	8,72	250	3500	77,8	87,8				
10A(C)3,15X254	3,15	4,44	10,36	250	3500	79,8	89,8				
10A(C)3,65X254	3,65	5,15	12,01	250	3500	81,9	91,9				
10A(C)4,2X254	4,2	5,92	13,82	250	3500	84,1	94,1				
* 10A(C)4,7X254	4,7	6,63	15,46	250	3500	87,1	96				
10A(C)5X254	5	7,05	14,10	250	3000	87,2	97,2				
10A(C)5,7X254	5,7	8,12	16,25	200	3000	90,1	100,1				
10A(C)6,1X254	6,1	8,69	14,49	200	2500	91,8	101,8				
10A(C)7,4X254	7,4	10,55	17,58	180	2500	97,2	107,2				
* 10A(C)8X254	8	11,40	15,20	150	2000	99,7	109,7				
10A(C)8,5X254	8,5	12,11	16,15	150	2000	101,7	111,7				
10A(C)9,8X254	9,8	13,97	18,62	120	2000	107	117				

* - These pumps - only under a special order

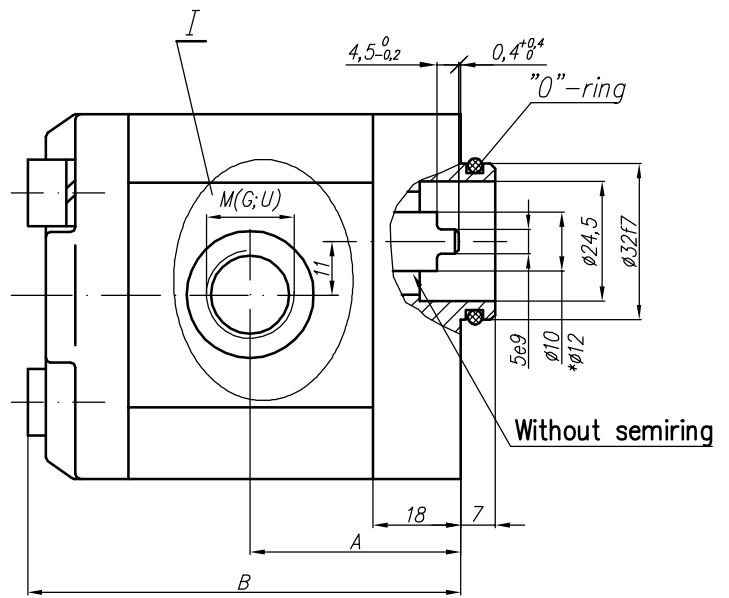
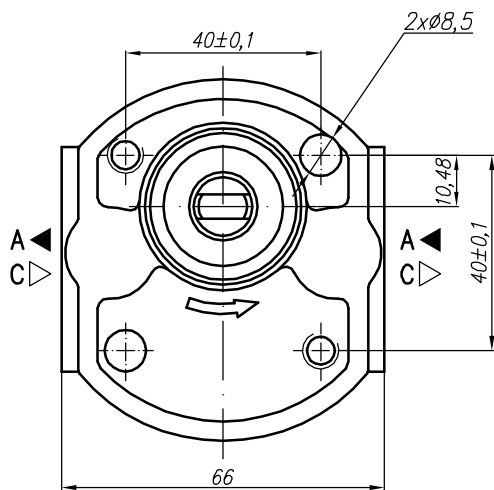

Variants:

...X255M - for M ports (see the picture I and the table below);

...X255G - for G ports (see the picture I and the table below);

...X255U - for U ports (see the picture I and the table below).

I – variants

Variant M

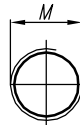

Variant G

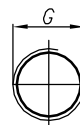

Variant U (SAEJ475 (ISO R725))

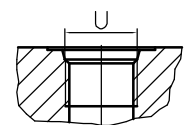

Type	Displacement cm ³ /rev	Flow		Pressure P _{nom} bar	max Speed n rpm	Dimension							
		at 1500 rpm l/min	at max rpm l/min			A mm	B mm	Inlet			Outlet		
								M	G	U	M	G	U
10A(C)1X255	1	1,40	3,26	250	3500	39,1	81	M18x1,5	G 3/8" - A	3/4" - 16UNF - 2B	M14x1,5	G 3/8" - A	9/16" - 18UNF - 2B
10A(C)1,25X255	1,25	1,74	4,07	250	3500	39,5	82						
10A(C)1,6X255	1,6	2,23	5,21	250	3500	40,3	83,6						
10A(C)2X255	2	2,82	6,58	250	3500	41,1	85,2						
10A(C)2,5X255	2,5	3,53	8,23	250	3500	42,1	87,2						
* 10A(C)2,65X255	2,65	3,74	8,72	250	3500	42,4	87,8		G 1/2" - A	3/4" - 16UNF - 2B	M14x1,5	G 3/8" - A	9/16" - 18UNF - 2B
10A(C)3,15X255	3,15	4,44	10,36	250	3500	43,5	89,8						
10A(C)3,65X255	3,65	5,15	12,01	250	3500	44,4	91,9						
10A(C)4,2X255	4,2	5,92	13,82	250	3500	45,5	94,1						
* 10A(C)4,7X255	4,7	6,63	15,46	250	3500	46,1	97,1						
10A(C)5X255	5	7,05	14,10	250	3000	47,1	97,2	M22x1,5	7/8" - 14UNF	M18x1,5	G 3/8" - A	3/4" - 16UNF	
10A(C)5,7X255	5,7	8,12	16,25	200	3000	48,5	100,1						
10A(C)6,1X255	6,1	8,69	14,49	200	2500	49,4	101,8						
10A(C)7,4X255	7,4	10,55	17,58	180	2500	52,1	107,2						
* 10A(C)8X255	8	11,40	15,20	150	2000	53,4	109,7						
10A(C)8,5X255	8,5	12,11	16,15	150	2000	54,4	111,7						
10A(C)9,8X255	9,8	13,97	18,62	120	2000	57	117						

* - These pumps - only under a special order

** - Shaft dia is 10 mm for displ. 1 ... 6,1 ccm and 12 mm for displ. 7,4 ccm and more

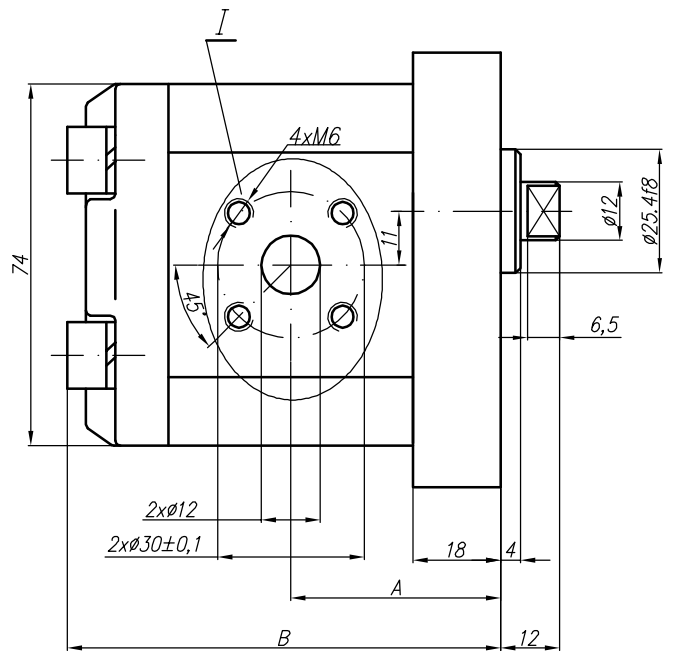
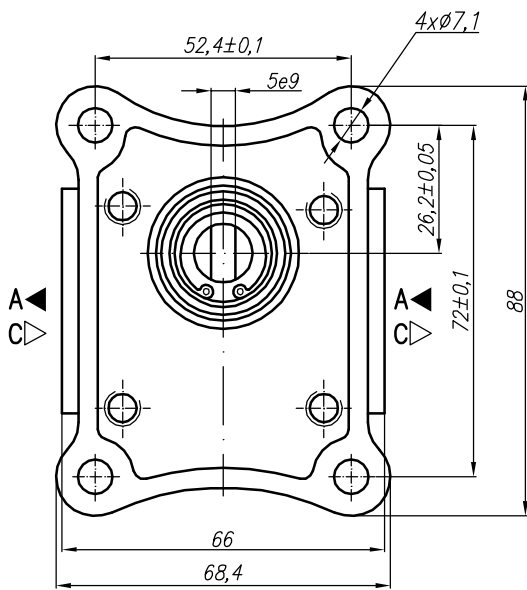

Variants:

- ...X257 - Normal version (flange);
- ...X257M - for M ports (see the picture I and the table below);
- ...X257G - for G ports (see the picture I and the table below);
- ...X257U - for U ports (see the picture I and the table below).

I - variants

Variant M



Variant G



Variant U (SAEJ475 (ISO R725))

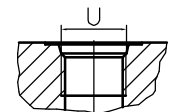

Type	Displacement cm ³ /rev	Flow		Pressure P _{nom} bar	max Speed n rpm	Dimension							
		at 1500 rpm l/min	at max rpm l/min			Inlet			Outlet				
						A mm	B mm	M	G	U	M	G	U
10A(C)1X257	1	1,40	3,26	250	3500	39,1	81	M16x1,5	G 3/8" - A	3/4" - 16UNF - 2B	M16x1,5	G 3/8" - A	9/16" - 18UNF - 2B
10A(C)1,25X257	1,25	1,74	4,07	250	3500	39,5	82						
10A(C)1,6X257	1,6	2,23	5,21	250	3500	40,3	83,6						
10A(C)2X257	2	2,82	6,58	250	3500	41,1	85,2						
10A(C)2,5X257	2,5	3,53	8,23	250	3500	42,1	87,2						
* 10A(C)2,65X257	2,65	3,74	8,72	250	3500	42,4	87,8	M20x1,5	G 1/2" - A	3/4" - 16UNF - 2B	M16x1,5	G 3/8" - A	9/16" - 18UNF - 2B
10A(C)3,15X257	3,15	4,44	10,36	250	3500	43,5	89,8						
10A(C)3,65X257	3,65	5,15	12,01	250	3500	44,4	91,9						
10A(C)4,2X257	4,2	5,92	13,82	250	3500	45,5	94,1						
* 10A(C)4,7X257	4,7	6,63	15,46	250	3500	46,1	96						
10A(C)5X257	5	7,05	14,10	250	3000	47,1	97,2	M22x1,5	G 1/2" - A	7/8" - 14UNF	M18x1,5	G 3/8" - A	3/4" - 16UNF
10A(C)5,7X257	5,7	8,12	16,25	200	3000	48,5	100,1						
10A(C)6,1X257	6,1	8,69	14,49	200	2500	49,4	101,8						
10A(C)7,4X257	7,4	10,55	17,58	180	2500	52,1	107,2						
* 10A(C)8X257	8	11,40	15,20	150	2000	53,4	109,7						
10A(C)8,5X257	8,5	12,11	16,15	150	2000	54,4	111,7	M22x1,5	G 1/2" - A	7/8" - 14UNF	M18x1,5	G 3/8" - A	3/4" - 16UNF
10A(C)9,8X257	9,8	13,97	18,62	120	2000	57	117						

* - These pumps - only under a special order

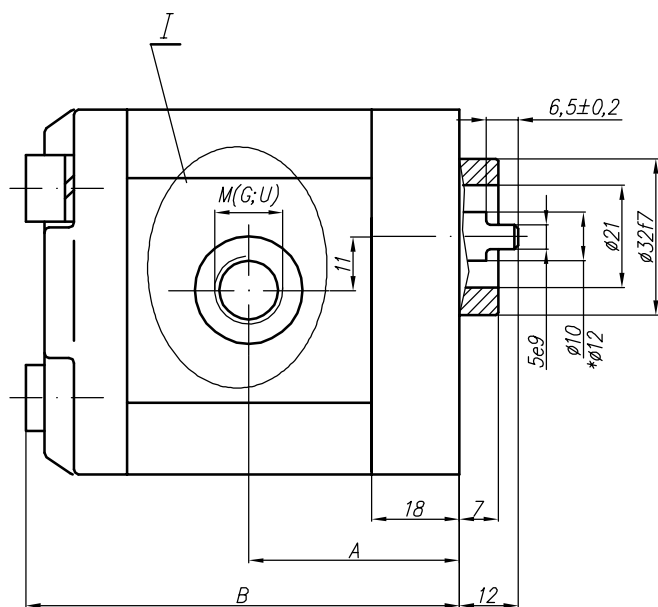
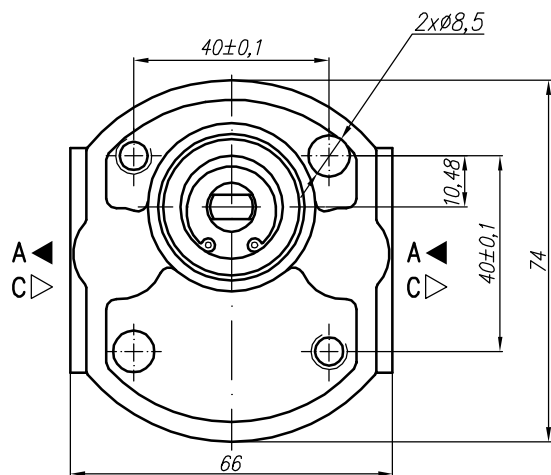

I – variants

Variants:

...X278M - for M ports (see the picture I and the table below);

...X278G - for G ports (see the picture I and the table below);

...X278U - for U ports (see the picture I and the table below).

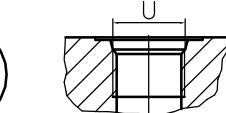
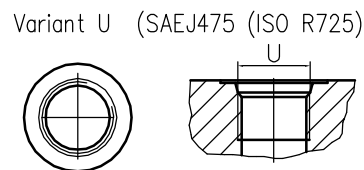
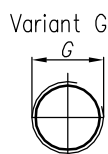
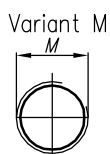

Type	Displacement cm ³ /rev	Flow		Pressure P _{nom} bar	max Speed n rpm	Dimension							
		at 1500 rpm l/min	at max rpm l/min			A mm	B mm	Inlet			Outlet		
								M	G	U	M	G	U
10A(C)1X278	1	1,40	3,26	250	3500	39,1	81	M16x1,5	G 3/8" - A	3/4" - 16UNF - 2B	M16x1,5	G 3/8" - A	9/16" - 18UNF - 2B
10A(C)1,25X278	1,25	1,74	4,07	250	3500	39,5	82						
10A(C)1,6X278	1,6	2,23	5,21	250	3500	40,3	83,6						
10A(C)2X278	2	2,82	6,58	250	3500	41,1	85,2						
10A(C)2,5X278	2,5	3,53	8,23	250	3500	42,1	87,2						
* 10A(C)2,65X278	2,65	3,74	8,72	250	3500	42,4	87,8	M20x1,5	G 1/2" - A	3/4" - 16UNF - 2B	M16x1,5	G 3/8" - A	9/16" - 18UNF - 2B
10A(C)3,15X278	3,15	4,44	10,36	250	3500	43,5	89,8						
10A(C)3,65X278	3,65	5,15	12,01	250	3500	44,4	91,9						
10A(C)4,2X278	4,2	5,92	13,82	250	3500	45,5	94,1						
* 10A(C)4,7X278	4,7	6,63	15,46	250	3500	46,1	96						
10A(C)5X278	5	7,05	14,10	250	3000	47,1	97,2	M22x1,5	G 1/2" - A	7/8" - 14UNF	M18x1,5	G 3/8" - A	3/4" - 16UNF
10A(C)5,7X278	5,7	8,12	16,25	200	3000	48,5	100,1						
10A(C)6,1X278	6,1	8,69	14,49	180	2500	49,4	101,8						
10A(C)7,4X278	7,4	10,55	17,58	180	2500	52,1	107,2						
* 10A(C)8X278	8	11,40	15,20	150	2000	53,4	109,7						
10A(C)8,5X278	8,5	12,11	16,15	150	2000	54,4	111,7	M22x1,5	G 1/2" - A	7/8" - 14UNF	M18x1,5	G 3/8" - A	3/4" - 16UNF
10A(C)9,8X278	9,8	13,97	18,62	120	2000	57	117						

* - These pumps - only under a special order

** - Shaft dia is 10 mm for displ. 1 ... 6,1 ccm and 12 mm for displ. 7,4 ccm and more

Rotation "A" - (anticlockwise)

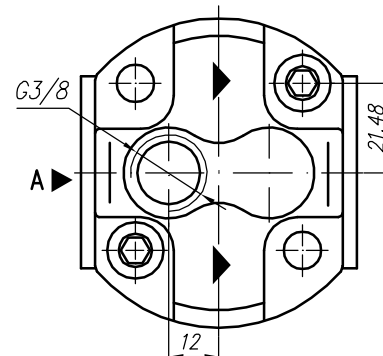
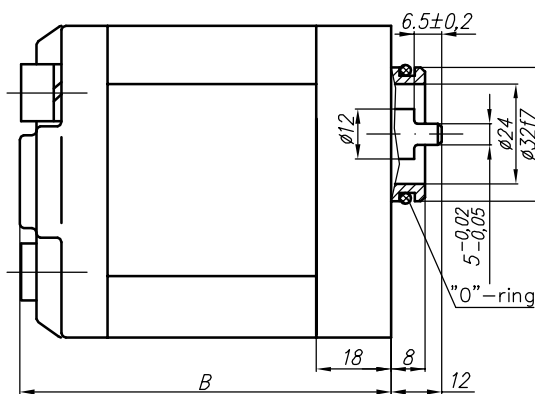
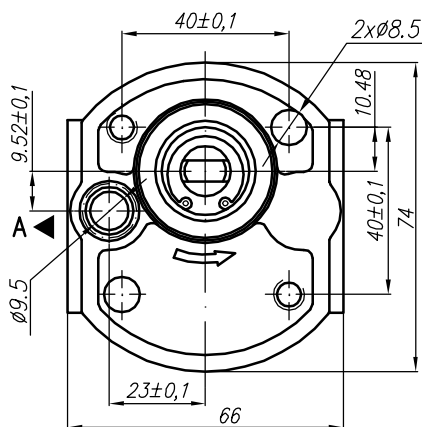

Rotation "C" - (clockwise)

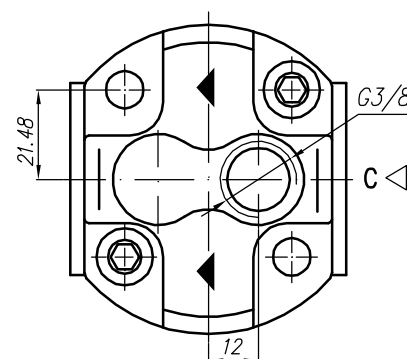
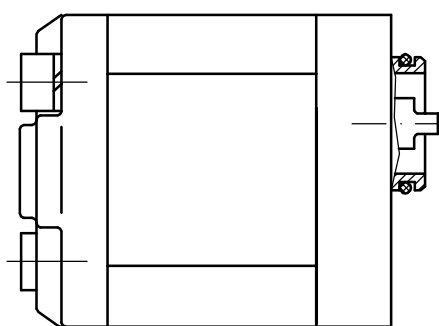
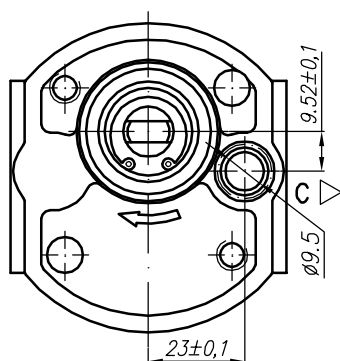

Type	Displacement cm ³ /rev	Flow		Pressure P _{nom} bar	max Speed n rpm	Dimension						
		at 1500 rpm l/min	at max rpm l/min			A mm	B mm	Inlet			Outlet	
								M	G	U		
10A(C)1X302	1	1,40	3,26	250	3500	71	81					
10A(C)1,25X302	1,25	1,74	4,07	250	3500	72	82					
10A(C)1,6X302	1,6	2,23	5,21	250	3500	73,6	83,6					
10A(C)2X302	2	2,82	6,58	250	3500	75,2	85,2					
10A(C)2,5X302	2,5	3,53	8,23	250	3500	77,2	87,2					
* 10A(C)2,65X302	2,65	3,74	8,72	250	3500	77,8	87,8					
10A(C)3,15X302	3,15	4,44	10,36	250	3500	79,8	89,8					
10A(C)3,65X302	3,65	5,15	12,01	250	3500	81,9	91,9					
10A(C)4,2X302	4,2	5,92	13,82	250	3500	84,1	94,1					
* 10A(C)4,7X302	4,7	6,63	15,46	250	3500	87,1	97,1					
10A(C)5X302	5	7,05	14,10	250	3000	87,2	97,2					
10A(C)5,7X302	5,7	8,12	16,25	200	3000	90,1	100,1					
10A(C)6,1X302	6,1	8,69	14,49	180	2500	91,8	101,8					
10A(C)7,4X302	7,4	10,55	17,58	180	2500	97,2	107,2					
* 10A(C)8X302	8	11,40	15,20	150	2000	99,7	109,7					
10A(C)8,5X302	8,5	12,11	16,15	150	2000	101,7	111,7					
10A(C)9,8X302	9,8	13,97	18,62	120	2000	107	117					

* - These pumps - only under a special order

The pump 10A(C)...X303 is a first section of a multiple pump Gr. 11 for mini power packs.

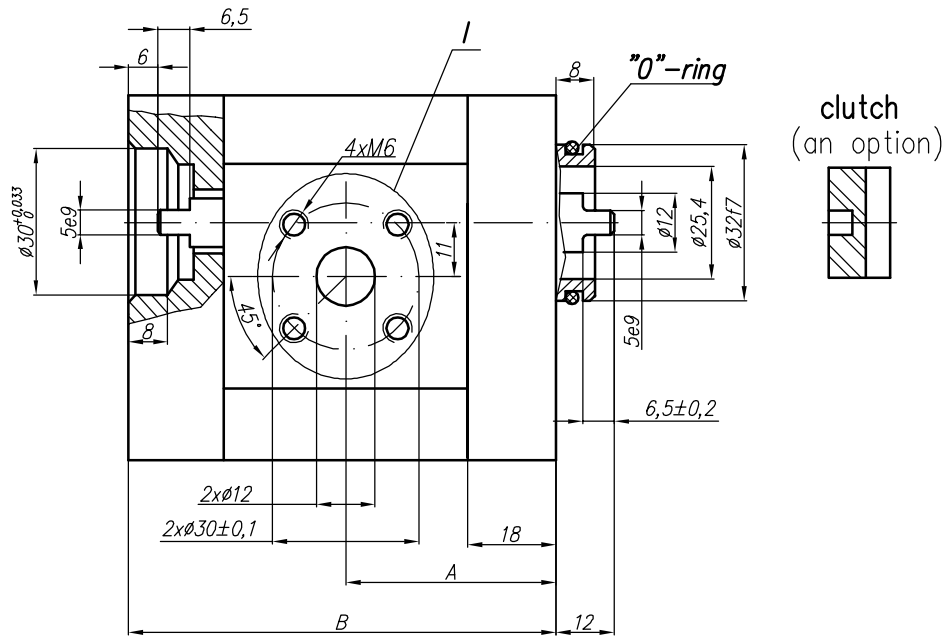
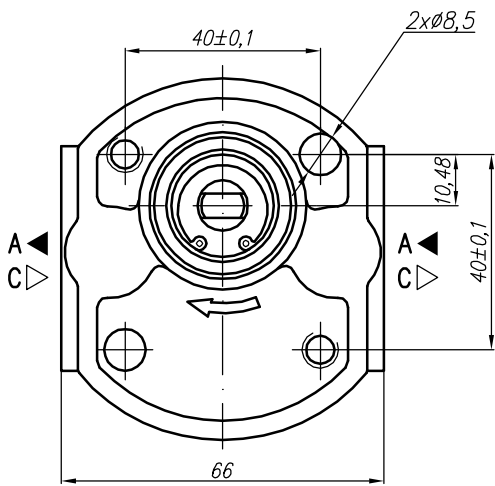

Variants:

- ...X303 - Normal version (flange);
- ...X303M - for M ports (see the picture I and the table below);
- ...X303G - for G ports (see the picture I and the table below);
- ...X303U - for U ports (see the picture I and the table below).

I – variants

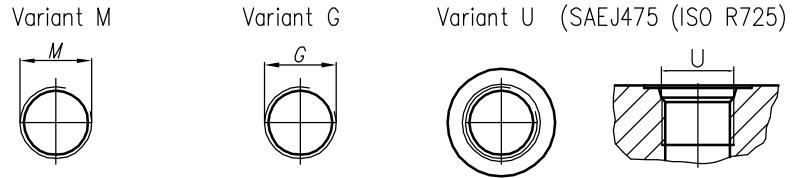

Type	Displacement cm ³ /rev	Flow		Pressure P _{nom} bar	max Speed n rpm	Dimension							
		at 1500 rpm l/min	at max rpm l/min			Inlet			Outlet				
						A mm	B mm	M	G	U	M	G	U
10A(C)1X303	1	1,40	3,26	250	3500	39,1	79	M16x1,5	G 3/8" - A	3/4" - 16UNF - 2B	M16x1,5	G 3/8" - A	9/16" - 18UNF - 2B
10A(C)1,25X303	1,25	1,74	4,07	250	3500	39,5	80						
10A(C)1,6X303	1,6	2,23	5,21	250	3500	40,3	81,6						
10A(C)2X303	2	2,82	6,58	250	3500	41,1	83,2						
10A(C)2,5X303	2,5	3,53	8,23	250	3500	42,1	85,2						
* 10A(C)2,65X303	2,65	3,74	8,72	250	3500	42,4	85,8	M20x1,5	G 1/2" - A	3/4" - 16UNF - 2B	M16x1,5	G 3/8" - A	9/16" - 18UNF - 2B
10A(C)3,15X303	3,15	4,44	10,36	250	3500	43,5	87,8						
10A(C)3,65X303	3,65	5,15	12,01	250	3500	44,4	89,9	M22x1,5	G 1/2" - A	7/8" - 14UNF	M18x1,5	G 3/8" - A	3/4" - 16UNF
10A(C)4,2X303	4,2	5,92	13,82	250	3500	45,5	92,1						
* 10A(C)4,7X303	4,7	6,63	15,46	250	3500	46,1	94						
10A(C)5X303	5	7,05	14,10	250	3000	47,1	95,2	M22x1,5	G 1/2" - A	7/8" - 14UNF	M18x1,5	G 3/8" - A	3/4" - 16UNF
10A(C)5,7X303	5,7	8,12	16,25	200	3000	48,5	98,1						
10A(C)6,1X303	6,1	8,69	14,49	200	2500	49,4	99,8						
10A(C)7,4X303	7,4	10,55	17,58	180	2500	52,1	105,2	M22x1,5	G 1/2" - A	7/8" - 14UNF	M18x1,5	G 3/8" - A	3/4" - 16UNF
* 10A(C)8X303	8	11,40	15,20	150	2000	53,4	107,7						
10A(C)8,5X303	8,5	12,11	16,15	150	2000	54,4	109,7						
10A(C)9,8X303	9,8	13,97	18,62	120	2000	57	115	M22x1,5	G 1/2" - A	7/8" - 14UNF	M18x1,5	G 3/8" - A	3/4" - 16UNF

* - These pumps - only under a special order

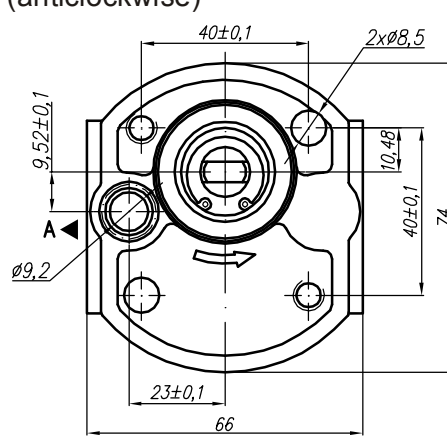
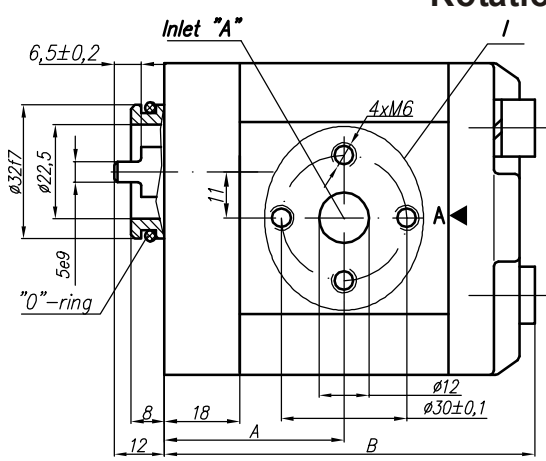

Rotation "C" - (clockwise)

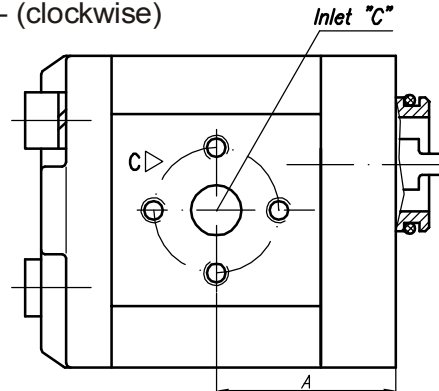
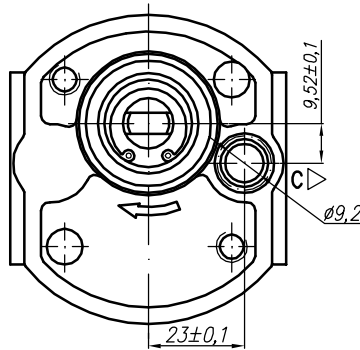

Variants:

- ...X330 - Normal version (flange);
- ...X330M - for M port (see the picture I and the table below);
- ...X330G - for G port (see the picture I and the table below);
- ...X330U - for U port (see the picture I and the table below).

I - variants (inlet only)

Variant M

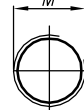

Variant G



Variant U (SAEJ475 (ISO R725))

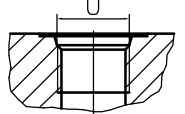
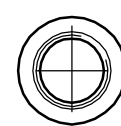

Type	Displacement cm ³ /rev	Flow		Pressure P _{nom} bar	max Speed n rpm	Dimension							
		at 1500 rpm l/min	at max rpm l/min			Inlet			Outlet				
						A mm	B mm	M	G	U	M	G	U
10A(C)1X330	1	1,40	3,26	250	3500	39,1	81	M16x1,5	G 3/8" - A	3/4" - 16UNF - 2B			
10A(C)1,25X330	1,25	1,74	4,07	250	3500	39,5	82						
10A(C)1,6X330	1,6	2,23	5,21	250	3500	40,3	83,6						
10A(C)2X330	2	2,82	6,58	250	3500	41,1	85,2						
10A(C)2,5X330	2,5	3,53	8,23	250	3500	42,1	87,2						
* 10A(C)2,65X330	2,65	3,74	8,72	250	3500	42,4	87,8	M20x1,5	G 1/2" - A	3/4" - 16UNF - 2B			
10A(C)3,15X330	3,15	4,44	10,36	250	3500	43,5	89,8						
10A(C)3,65X330	3,65	5,15	12,01	250	3500	44,4	91,9						
10A(C)4,2X330	4,2	5,92	13,82	250	3500	45,5	94,1						
* 10A(C)4,7X330	4,7	6,63	15,46	250	3500	46,1	96						
10A(C)5X330	5	7,05	14,10	250	3000	47,1	97,2	M22x1,5	G 1/2" - A	7/8" - 14UNF			
10A(C)5,7X330	5,7	8,12	16,25	200	3000	48,5	100,1						
10A(C)6,1X330	6,1	8,69	14,49	180	2500	49,4	101,8						
10A(C)7,4X330	7,4	10,55	17,58	180	2500	52,1	107,2						
* 10A(C)8X330	8	11,40	15,20	150	2000	53,4	109,7						
10A(C)8,5X330	8,5	12,11	16,15	150	2000	54,4	111,7						
10A(C)9,8X330	9,8	13,97	18,62	120	2000	57	117						

* - These pumps - only under a special order

Rotation "A" - (anticlockwise)

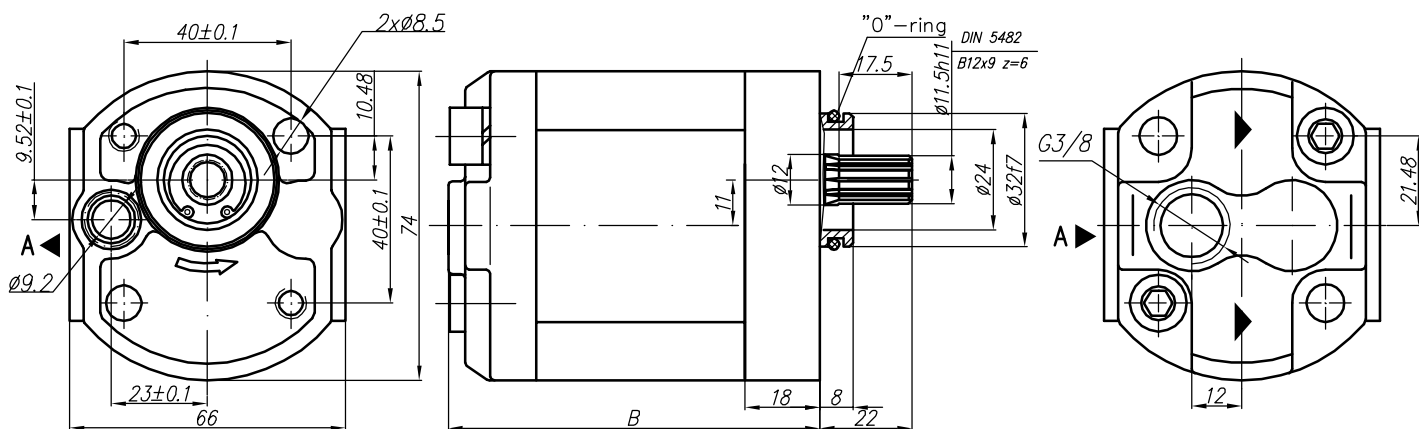

Rotation "C" - (clockwise)

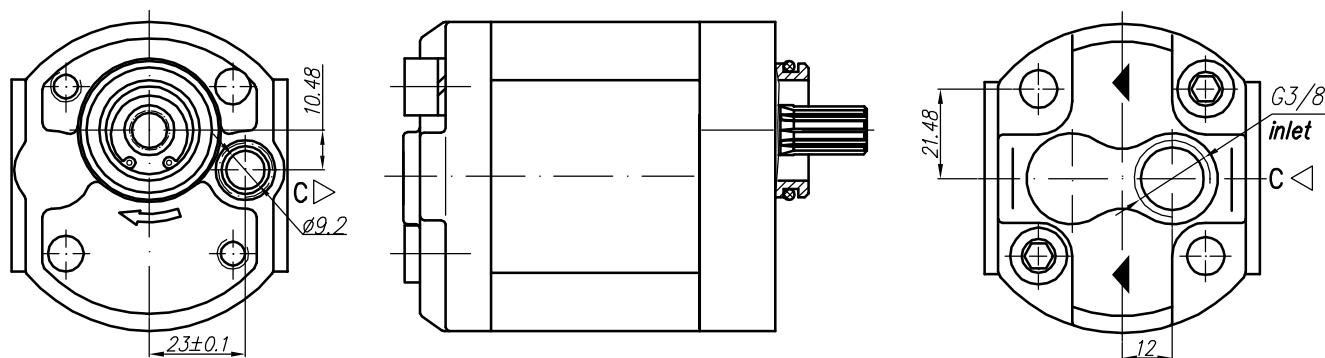

Type	Displacement cm ³ /rev	Flow		Pressure P _{nom} bar	max Speed n rpm	Dimension							
		at 1500 rpm l/min	at max rpm l/min			Inlet			Outlet				
						A mm	B mm	M	G	U			
10A(C)1X340	1	1,40	3,26	250	3500		81	G 3/8" - A					∅9,2
10A(C)1,25X340	1,25	1,74	4,07	250	3500		82						
10A(C)1,6X340	1,6	2,23	5,21	250	3500		83,6						
10A(C)2X340	2	2,82	6,58	250	3500		85,2						
10A(C)2,5X340	2,5	3,53	8,23	250	3500		87,2						
* 10A(C)2,65X340	2,65	3,74	8,72	250	3500		87,8						
10A(C)3,15X340	3,15	4,44	10,36	250	3500		89,8						
10A(C)3,65X340	3,65	5,15	12,01	250	3500		91,9						
10A(C)4,2X340	4,2	5,92	13,82	250	3500		94,1						
* 10A(C)4,7X340	4,7	6,63	15,46	250	3500		97,1						
10A(C)5X340	5	7,05	14,10	250	3000		97,2						
10A(C)5,7X340	5,7	8,12	16,25	200	3000		100,1						
10A(C)6,1X340	6,1	8,69	14,49	180	2500		101,8						
10A(C)7,4X340	7,4	10,55	17,58	180	2500		107,2						
* 10A(C)8X340	8	11,40	15,20	150	2000		109,7						
10A(C)8,5X340	8,5	12,11	16,15	150	2000		111,7						
10A(C)9,8X340	9,8	13,97	18,62	120	2000		117						

* - These pumps - only under a special order

The pump 10A(C)...X343 is a middle section of a multiple pump Gr. 211 or 311.

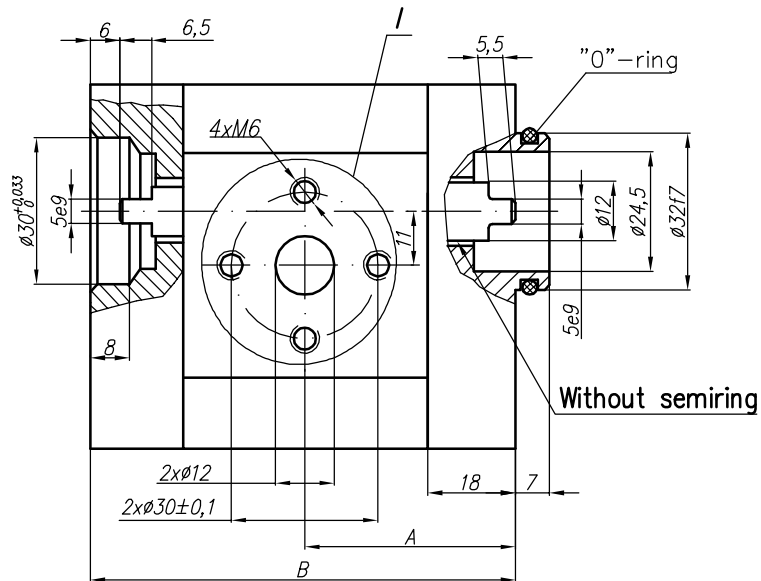
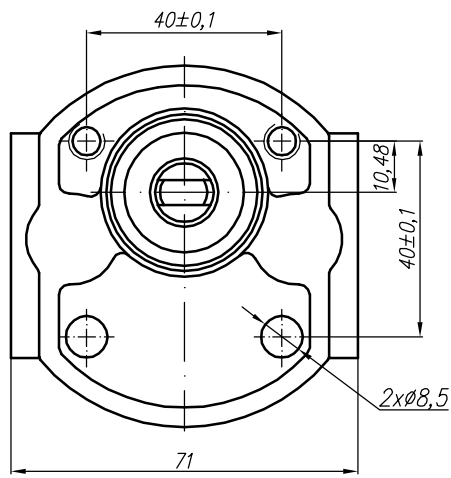

Variants:

- ...X343 - Normal version (flange);
- ...X343M - for M ports (see the picture I and the table below);
- ...X343G - for G ports (see the picture I and the table below);
- ...X343U - for U ports (see the picture I and the table below).

I - variants

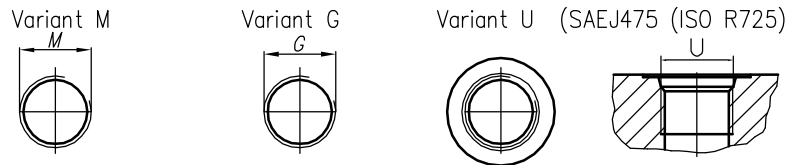

Type	Displacement cm ³ /rev	Flow		Pressure P _{nom} bar	max Speed n rpm	Dimension							
		at 1500 rpm l/min	at max rpm l/min			Inlet			Outlet				
						A mm	B mm	M	G	U	M	G	U
10A(C)1X343	1	1,40	3,26	250	3500	39,1	79	M16x1,5	G 3/8" - A	3/4" - 16UNF - 2B	M16x1,5	G 3/8" - A	9/16" - 18UNF - 2B
10A(C)1,25X343	1,25	1,74	4,07	250	3500	39,5	80						
10A(C)1,6X343	1,6	2,23	5,21	250	3500	40,3	81,6						
10A(C)2X343	2	2,82	6,58	250	3500	41,1	83,2						
10A(C)2,5X343	2,5	3,53	8,23	250	3500	42,1	85,2	M20x1,5	G 1/2" - A	3/4" - 16UNF - 2B	M16x1,5	G 3/8" - A	9/16" - 18UNF - 2B
* 10A(C)2,65X343	2,65	3,74	8,72	250	3500	42,4	85,8						
10A(C)3,15X343	3,15	4,44	10,36	250	3500	43,5	87,8	M22x1,5	G 1/2" - A	7/8" - 14UNF	M18x1,5	G 3/8" - A	3/4" - 16UNF
10A(C)3,65X343	3,65	5,15	12,01	250	3500	44,4	89,9						
10A(C)4,2X343	4,2	5,92	13,82	250	3500	45,5	92,1	M22x1,5	G 1/2" - A	7/8" - 14UNF	M18x1,5	G 3/8" - A	3/4" - 16UNF
* 10A(C)4,7X343	4,7	6,63	15,46	250	3500	46,1	94						
10A(C)5X343	5	7,05	14,10	250	3000	47,1	95,2	M22x1,5	G 1/2" - A	7/8" - 14UNF	M18x1,5	G 3/8" - A	3/4" - 16UNF
10A(C)5,7X343	5,7	8,12	16,25	200	3000	48,5	98,1						
10A(C)6,1X343	6,1	8,69	14,49	200	2500	49,4	99,8	M22x1,5	G 1/2" - A	7/8" - 14UNF	M18x1,5	G 3/8" - A	3/4" - 16UNF
10A(C)7,4X343	7,4	10,55	17,58	180	2500	52,1	105,2						
* 10A(C)8X343	8	11,40	15,20	150	2000	53,4	107,7	M22x1,5	G 1/2" - A	7/8" - 14UNF	M18x1,5	G 3/8" - A	3/4" - 16UNF
10A(C)8,5X343	8,5	12,11	16,15	150	2000	54,4	109,7						
10A(C)9,8X343	9,8	13,97	18,62	120	2000	57	115	M22x1,5	G 1/2" - A	7/8" - 14UNF	M18x1,5	G 3/8" - A	3/4" - 16UNF

* - These pumps - only under a special order

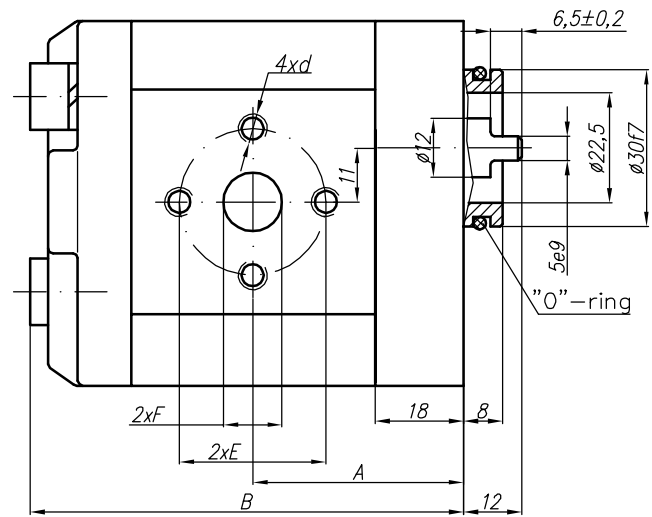
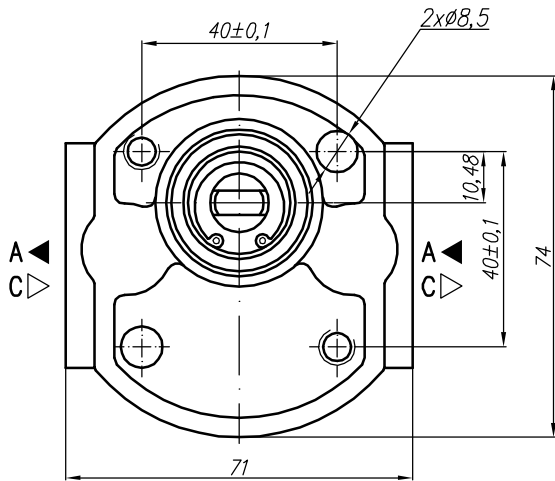

Type	Displacement cm ³ /rev	Flow		Pressure P _{nom} bar	max Speed n rpm	Dimension							
		at 1500 rpm l/min	at max rpm l/min			Inlet			Outlet				
						A mm	B mm	E	F	d	E	F	d
10A(C)1X375	1	1,40	3,26	250	3500	39,1	81						
10A(C)1,25X375	1,25	1,74	4,07	250	3500	39,5	82						
10A(C)1,6X375	1,6	2,23	5,21	250	3500	40,3	83,6						
10A(C)2X375	2	2,82	6,58	250	3500	41,1	85,2						
10A(C)2,5X375	2,5	3,53	8,23	250	3500	42,1	87,2						
* 10A(C)2,65X375	2,65	3,74	8,72	250	3500	42,4	87,8						
10A(C)3,15X375	3,15	4,44	10,36	250	3500	43,5	89,8						
10A(C)3,65X375	3,65	5,15	12,01	250	3500	44,4	91,9						
10A(C)4,2X375	4,2	5,92	13,82	250	3500	45,5	94,1	Ø30	Ø12	M6	Ø30	Ø12	M6
* 10A(C)4,7X375	4,7	6,63	15,46	250	3500	46,1	97,1						
10A(C)5X375	5	7,05	14,10	250	3000	47,1	97,2						
10A(C)5,7X375	5,7	8,12	16,25	200	3000	48,5	100,1						
10A(C)6,1X375	6,1	8,69	14,49	200	2500	49,4	101,8						
10A(C)7,4X375	7,4	10,55	17,58	180	2500	52,1	107,2						
* 10A(C)8X375	8	11,40	15,20	150	2000	53,4	109,7						
10A(C)8,5X375	8,5	12,11	16,15	150	2000	54,4	111,7						
10A(C)9,8X375	9,8	13,97	18,62	120	2000	57	117						

* - These pumps - only under a special order

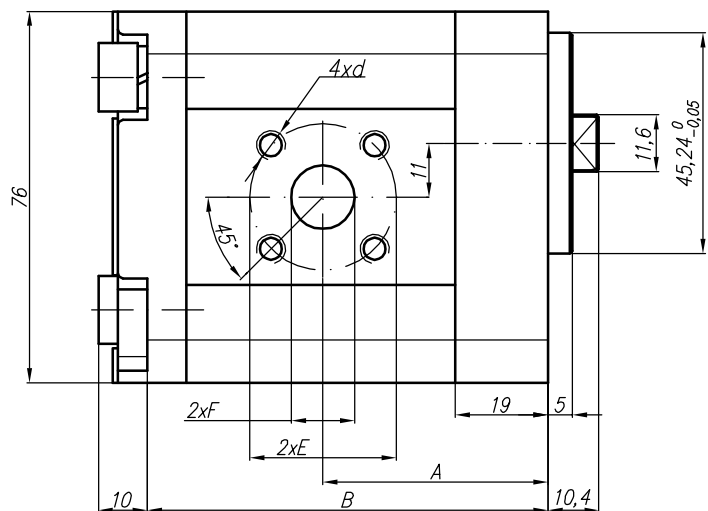
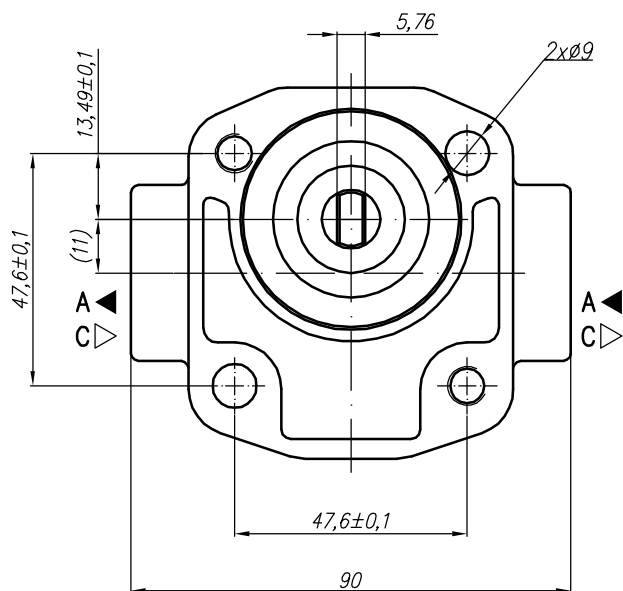

Type	Displacement cm ³ /rev	Flow		Pressure P _{nom} bar	max Speed n rpm	Dimension							
		at 1500 rpm l/min	at max rpm l/min			Inlet			Outlet				
						A mm	B mm	E	F	d	E	F	d
10A(C)1X394	1	1,40	3,26	250	3500	40,1	69,1	ø30	ø13	M6	ø30	ø13	M6
10A(C)1,25X394	1,25	1,74	4,07	250	3500	40,6	70,1						
10A(C)1,6X394	1,6	2,23	5,21	250	3500	41,3	71,5						
10A(C)2X394	2	2,82	6,58	250	3500	42,1	73,2						
10A(C)2,5X394	2,5	3,53	8,23	250	3500	43,1	75,2						
* 10A(C)2,65X394	2,65	3,74	8,72	250	3500	43,4	75,8						
10A(C)3,15X394	3,15	4,44	10,36	250	3500	44,5	77,8						
10A(C)3,65X394	3,65	5,15	12,01	250	3500	45,4	79,8						
10A(C)4,2X394	4,2	5,92	13,82	250	3500	46,5	82,0						
* 10A(C)4,7X394	4,7	6,63	15,46	250	3500	47,5	84,1						
10A(C)5X394	5	7,05	14,10	250	3000	48,1	85,2						
10A(C)5,7X394	5,7	8,12	16,25	200	3000	49,5	88,0						
10A(C)6,1X394	6,1	8,69	14,49	200	2500	50,4	89,8						
10A(C)7,4X394	7,4	10,55	17,58	180	2500	53,1	95,3						
* 10A(C)8X394	8	11,40	15,20	150	2000	54,4	97,7						
10A(C)8,5X394	8,5	12,11	16,15	150	2000	55,4	99,8						
10A(C)9,8X394	9,8	13,97	18,62	120	2000	58,0	105,0						

* - These pumps - only under a special order

Rotation "A" - (anticlockwise)

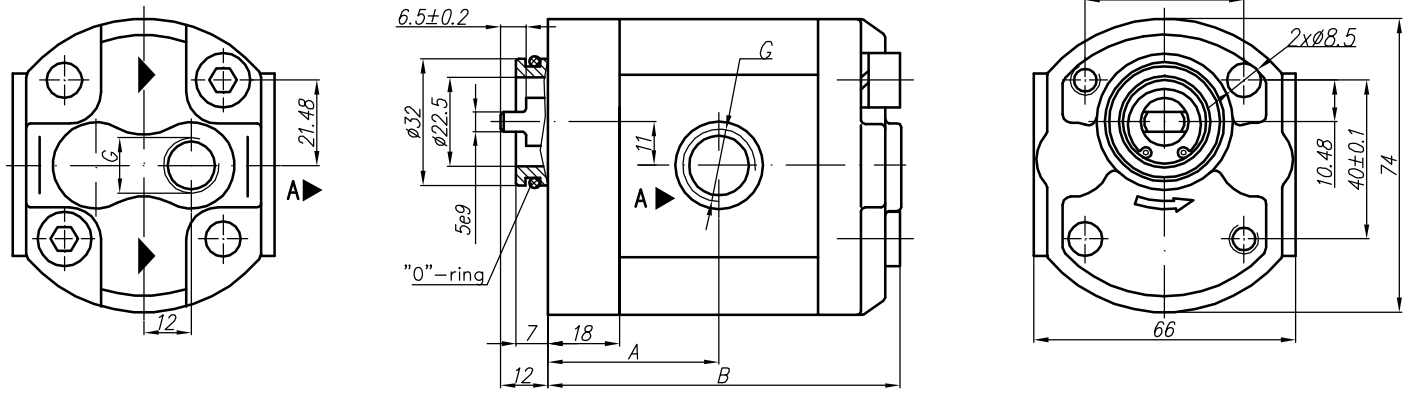

Rotation "C" - (clockwise)

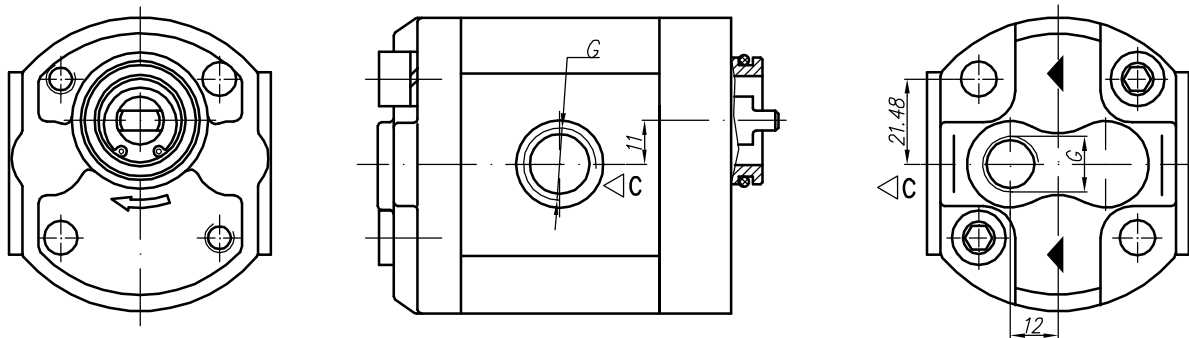

Type	Displacement cm ³ /rev	Flow		Pressure P _{nom} bar	max Speed n rpm	Dimension						
		at 1500 rpm l/min	at max rpm l/min			A mm	B mm	Inlet G		Outlet G		
10A(C)1X400	1	1,40	3,26	250	3500	39,1	81	G 3/8" - A				
10A(C)1,25X400	1,25	1,74	4,07	250	3500	39,5	82					
10A(C)1,6X400	1,6	2,23	5,21	250	3500	40,3	83,6					
10A(C)2X400	2	2,82	6,58	250	3500	41,1	85,2					
10A(C)2,5X400	2,5	3,53	8,23	250	3500	42,1	87,2					
* 10A(C)2,65X400	2,65	3,74	8,72	250	3500	42,4	87,8	G 1/2" - A				
10A(C)3,15X400	3,15	4,44	10,36	250	3500	43,5	89,8					
10A(C)3,65X400	3,65	5,15	12,01	250	3500	44,4	91,9					
10A(C)4,2X400	4,2	5,92	13,82	250	3500	45,5	94,1					
* 10A(C)4,7X400	4,7	6,63	15,46	250	3500	46,1	97,1					
10A(C)5X400	5	7,05	14,10	250	3000	47,1	97,2					
10A(C)5,7X400	5,7	8,12	16,25	200	3000	48,5	100,1					
10A(C)6,1X400	6,1	8,69	14,49	200	2500	49,4	101,8					
10A(C)7,4X400	7,4	10,55	17,58	180	2500	52,1	107,2					
* 10A(C)8X400	8	11,40	15,20	150	2000	53,4	109,7					
10A(C)8,5X400	8,5	12,11	16,15	150	2000	54,4	111,7					
10A(C)9,8X400	9,8	13,97	18,62	120	2000	57	117					

* - These pumps - only under a special order

The pump 10A(C)...X416 is a first section of a multiple pump Gr.11.

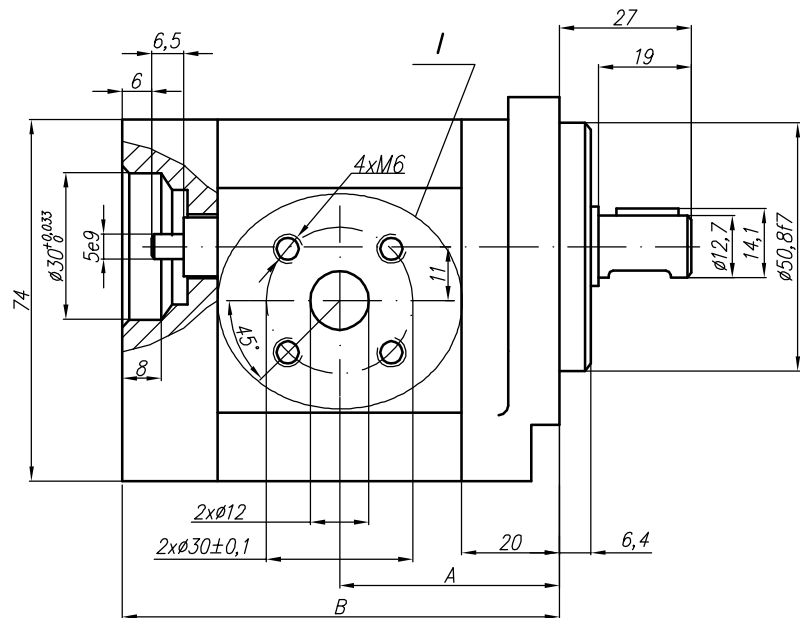
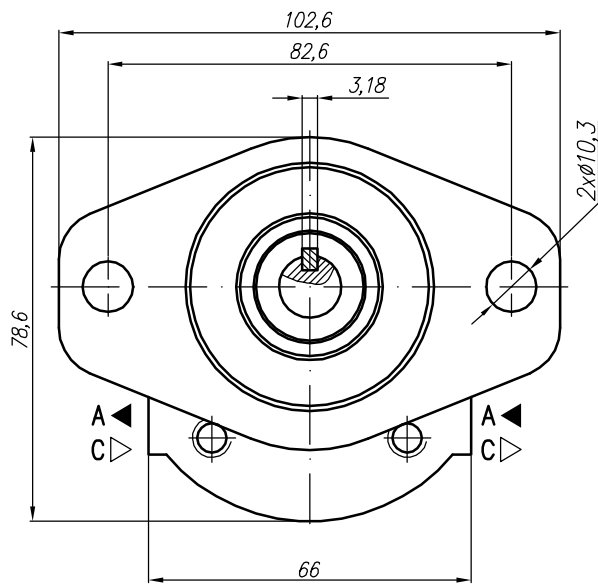

I - variants

Variants:

- ...X416 - Normal version (flange);
- ...X416M - for M ports (see the picture I and the table below);
- ...X416G - for G ports (see the picture I and the table below);
- ...X416U - for U ports (see the picture I and the table below).

Variant M



Variant G

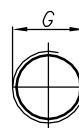

Variant U (SAEJ475 (ISO R725))

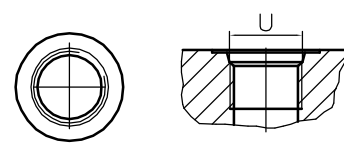

Type	Displacement cm ³ /rev	Flow		Pressure P _{nom} bar	max Speed n rpm	Dimension							
		at 1500 rpm l/min	at max rpm l/min			A mm	B mm	Inlet			Outlet		
								M	G	U	M	G	U
10A(C)1X416	1	1,40	3,26	250	3500	41,1	83	M16x1,5	G 3/8" - A	3/4" - 16UNF - 2B	M16x1,5	G 3/8" - A	9/16" - 18UNF - 2B
10A(C)1,25X416	1,25	1,74	4,07	250	3500	41,5	84						
10A(C)1,6X416	1,6	2,23	5,21	250	3500	42,3	85,6						
10A(C)2X416	2	2,82	6,58	250	3500	43,1	87,2						
10A(C)2,5X416	2,5	3,53	8,23	250	3500	44,1	89,2						
10A(C)2,65X416	2,65	3,74	8,72	250	3500	44,4	89,8	M20x1,5	G 1/2" - A	3/4" - 16UNF - 2B	M16x1,5	G 3/8" - A	9/16" - 18UNF - 2B
10A(C)3,15X416	3,15	4,44	10,36	250	3500	45,5	91,8						
10A(C)3,65X416	3,65	5,15	12,01	250	3500	46,4	93,9						
10A(C)4,2X416	4,2	5,92	13,82	250	3500	47,5	96,1	M22x1,5	G 1/2" - A	7/8" - 14UNF	M18x1,5	G 3/8" - A	3/4" - 16UNF
* 10A(C)4,7X416	4,7	6,63	15,46	250	3500	48,5	98						
10A(C)5X416	5	7,05	14,10	250	3000	49,1	99,2	M22x1,5	G 1/2" - A	7/8" - 14UNF	M18x1,5	G 3/8" - A	3/4" - 16UNF
10A(C)5,7X416	5,7	8,12	16,25	200	3000	50,5	102						
10A(C)6,1X416	6,1	8,69	14,49	200	2500	51,4	103,8						
10A(C)7,4X416	7,4	10,55	17,58	180	2500	54,1	109,2	M22x1,5	G 1/2" - A	7/8" - 14UNF	M18x1,5	G 3/8" - A	3/4" - 16UNF
* 10A(C)8X416	8	11,40	15,20	150	2000	55,4	111,7						
10A(C)8,5X416	8,5	12,11	16,15	150	2000	56,4	113,7	M22x1,5	G 1/2" - A	7/8" - 14UNF	M18x1,5	G 3/8" - A	3/4" - 16UNF
10A(C)9,8X416	9,8	13,97	18,62	120	2000	59	119						

* - These pumps - only under a special order

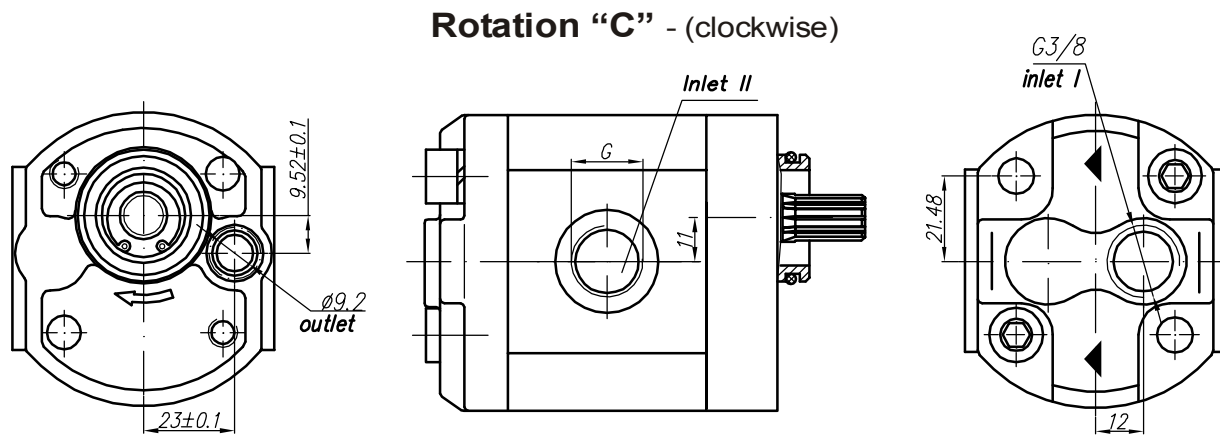
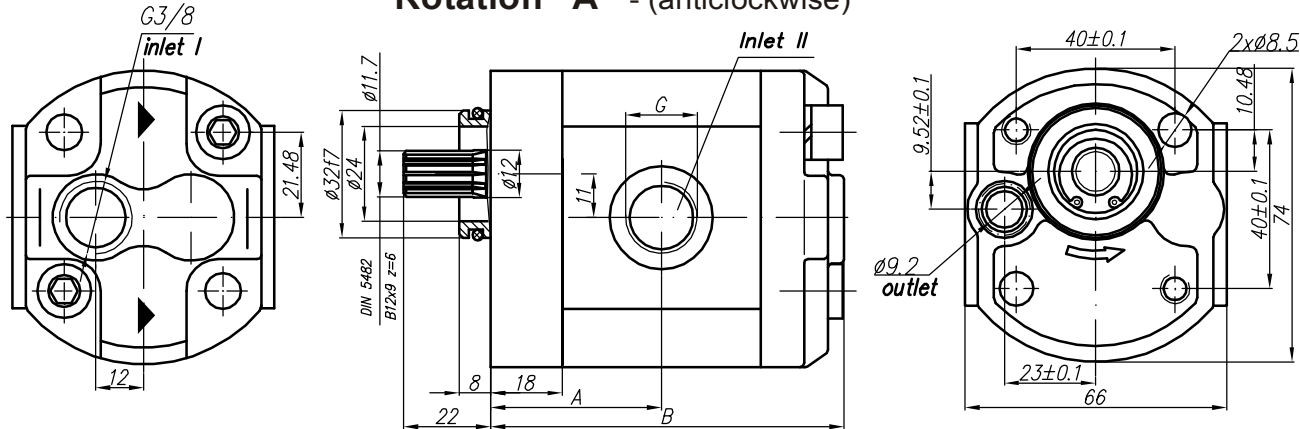

Type	Displacement cm ³ /rev	Flow		Pressure P _{nom} bar	max Speed n rpm	Dimension						
		at 1500 rpm l/min	at max rpm l/min			A mm	B mm	Inlet		Outlet		
10A(C)1X417	1	1,40	3,26	250	3500	71	81	G 3/8" - A	G 1/4" - A	Ø9,2		
10A(C)1,25X417	1,25	1,74	4,07	250	3500	72	82					
10A(C)1,6X417	1,6	2,23	5,21	250	3500	73,6	83,6					
10A(C)2X417	2	2,82	6,58	250	3500	75,2	85,2					
10A(C)2,5X417	2,5	3,53	8,23	250	3500	77,2	87,2					
* 10A(C)2,65X417	2,65	3,74	8,72	250	3500	77,8	87,8					
10A(C)3,15X417	3,15	4,44	10,36	250	3500	79,8	89,8					
10A(C)3,65X417	3,65	5,15	12,01	250	3500	81,9	91,9					
10A(C)4,2X417	4,2	5,92	13,82	250	3500	84,1	94,1					
* 10A(C)4,7X417	4,7	6,63	15,46	250	3500	87,1	97,1					
10A(C)5X417	5	7,05	14,10	250	3000	87,2	97,2					
10A(C)5,7X417	5,7	8,12	16,25	200	3000	90,1	100,1					
10A(C)6,1X417	6,1	8,69	14,49	200	2500	91,8	101,8					
10A(C)7,4X417	7,4	10,55	17,58	180	2500	97,2	107,2					
* 10A(C)8X417	8	11,40	15,20	150	2000	99,7	109,7					
10A(C)8,5X417	8,5	12,11	16,15	150	2000	101,7	111,7					
10A(C)9,8X417	9,8	13,97	18,62	120	2000	107	117					

* - These pumps - only under a special order

The pump is similar to "1GAS - Marzocchi" - (difference at shaft dia and the cone)

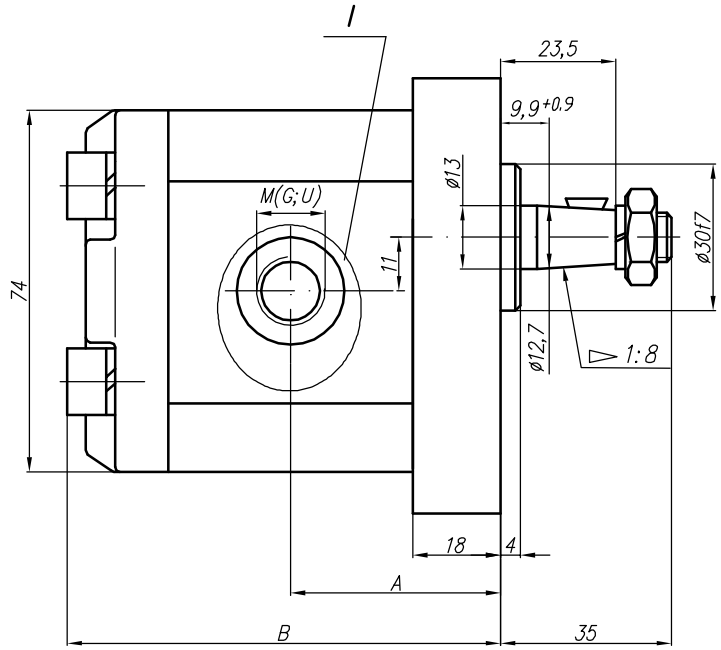
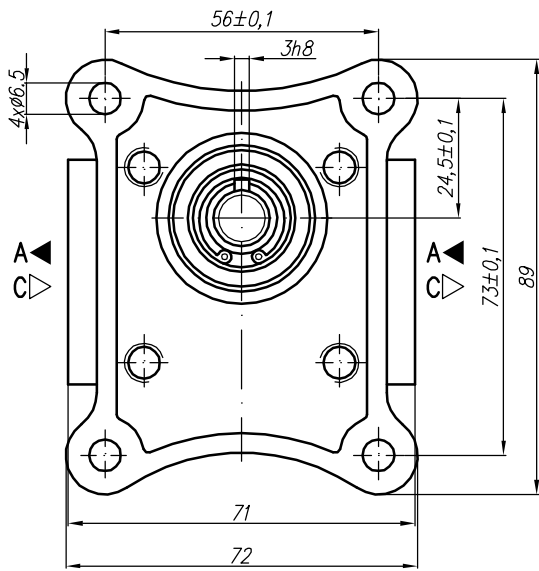

Variants:

- ...X418M - for M ports (see the picture I and the table below);
- ...X418G - for G ports (see the picture I and the table below);
- ...X418U - for U ports (see the picture I and the table below).

I - variants

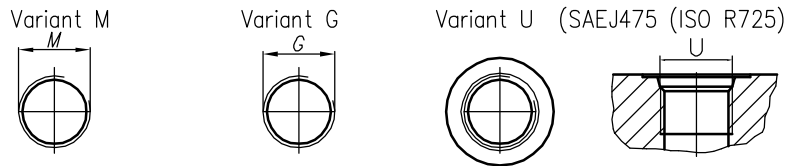

Type	Displacement cm ³ /rev	Flow		Pressure P _{nom} bar	max Speed n rpm	Dimension							
		at 1500 rpm l/min	at max rpm l/min			A mm	B mm	Inlet			Outlet		
								M	G	U	M	G	U
10A(C)1X418	1	1,40	3,26	250	3500	39,1	81	M16x1,5	G 3/8" - A	3/4" - 16UNF - 2B	M16x1,5	G 3/8" - A	9/16" - 18UNF - 2B
10A(C)1,25X418	1,25	1,74	4,07	250	3500	39,5	82						
10A(C)1,6X418	1,6	2,23	5,21	250	3500	40,3	83,6						
10A(C)2X418	2	2,82	6,58	250	3500	41,1	85,2						
10A(C)2,5X418	2,5	3,53	8,23	250	3500	42,1	87,2	M20x1,5	G 1/2" - A	3/4" - 16UNF - 2B	M16x1,5	G 3/8" - A	9/16" - 18UNF - 2B
* 10A(C)2,65X418	2,65	3,74	8,72	250	3500	42,4	87,8						
10A(C)3,15X418	3,15	4,44	10,36	250	3500	43,5	89,8	M22x1,5	G 1/2" - A	7/8" - 14UNF	M18x1,5	G 3/8" - A	3/4" - 16UNF
10A(C)3,65X418	3,65	5,15	12,01	250	3500	44,4	91,9						
10A(C)4,2X418	4,2	5,92	13,82	250	3500	45,5	94,1	M22x1,5	G 1/2" - A	7/8" - 14UNF	M18x1,5	G 3/8" - A	3/4" - 16UNF
* 10A(C)4,7X418	4,7	6,63	15,46	250	3500	46,1	97,1						
10A(C)5X418	5	7,05	14,10	250	3000	47,1	97,2	M22x1,5	G 1/2" - A	7/8" - 14UNF	M18x1,5	G 3/8" - A	3/4" - 16UNF
10A(C)5,7X418	5,7	8,12	16,25	200	3000	48,5	100,1						
10A(C)6,1X418	6,1	8,69	14,49	200	2500	49,4	101,8	M22x1,5	G 1/2" - A	7/8" - 14UNF	M18x1,5	G 3/8" - A	3/4" - 16UNF
10A(C)7,4X418	7,4	10,55	17,58	180	2500	52,1	107,2						
* 10A(C)8X418	8	11,40	15,20	150	2000	53,4	109,7	M22x1,5	G 1/2" - A	7/8" - 14UNF	M18x1,5	G 3/8" - A	3/4" - 16UNF
10A(C)8,5X418	8,5	12,11	16,15	150	2000	54,4	111,7						
10A(C)9,8X418	9,8	13,97	18,62	120	2000	57	117	M22x1,5	G 1/2" - A	7/8" - 14UNF	M18x1,5	G 3/8" - A	3/4" - 16UNF

* - These pumps - only under a special order

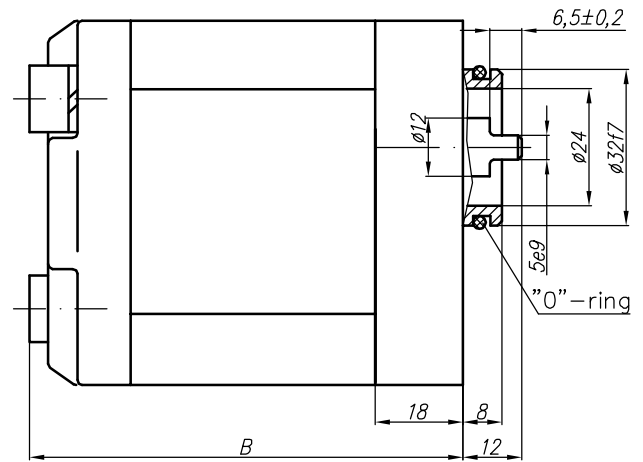
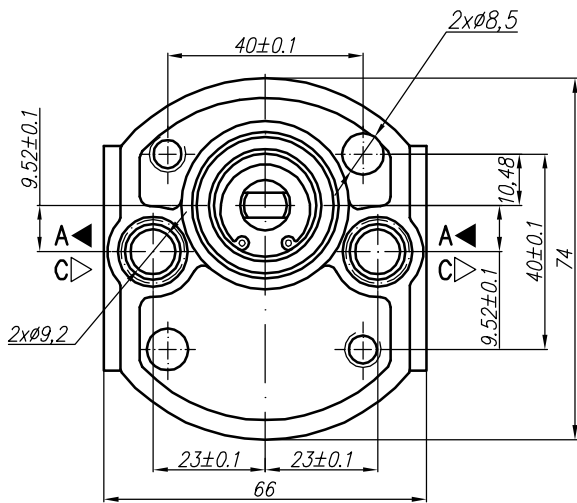

Type	Displacement cm ³ /rev	Flow		Pressure P _{nom} bar	max Speed n rpm	Dimension							
		at 1500 rpm l/min	at max rpm l/min			A mm	B mm	Inlet		Outlet			
10A(C)1X442	1	1,40	3,26	250	3500		81						
10A(C)1,25X442	1,25	1,74	4,07	250	3500		82						
10A(C)1,6X442	1,6	2,23	5,21	250	3500		83,6						
10A(C)2X442	2	2,82	6,58	250	3500		85,2						
10A(C)2,5X442	2,5	3,53	8,23	250	3500		87,2						
* 10A(C)2,65X442	2,65	3,74	8,72	250	3500		87,8						
10A(C)3,15X442	3,15	4,44	10,36	250	3500		89,8						
10A(C)3,65X442	3,65	5,15	12,01	250	3500		91,9						
10A(C)4,2X442	4,2	5,92	13,82	250	3500		94,1			Ø9,2		Ø9,2	
* 10A(C)4,7X442	4,7	6,63	15,46	250	3500		97,1						
10A(C)5X442	5	7,05	14,10	250	3000		97,2						
10A(C)5,7X442	5,7	8,12	16,25	200	3000		100,1						
10A(C)6,1X442	6,1	8,69	14,49	200	2500		101,8						
10A(C)7,4X442	7,4	10,55	17,58	180	2500		107,2						
* 10A(C)8X442	8	11,40	15,20	150	2000		109,7						
10A(C)8,5X442	8,5	12,11	16,15	150	2000		111,7						
10A(C)9,8X442	9,8	13,97	18,62	120	2000		117						

* - These pumps - only under a special order

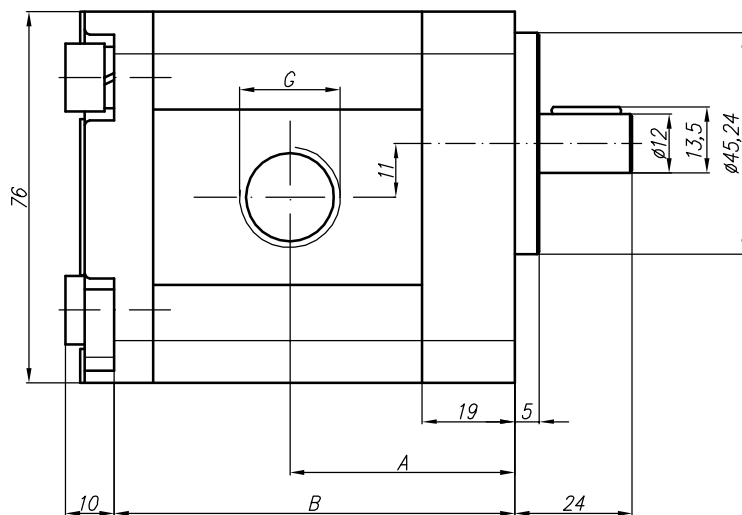
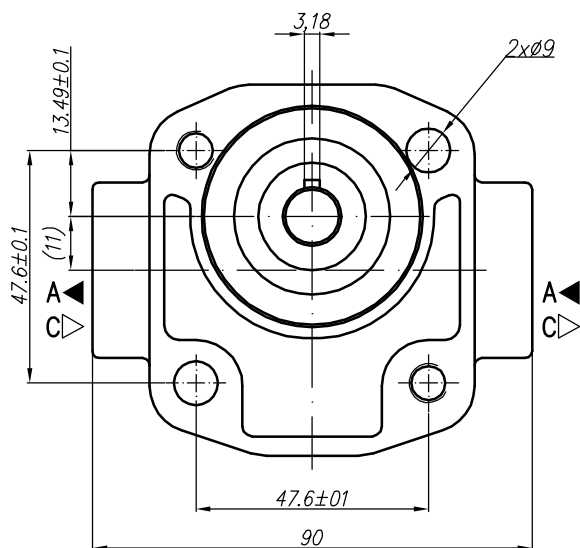

Type	Displacement cm ³ /rev	Flow		Pressure P _{nom} bar	max Speed n rpm	Dimension								
		at 1500 rpm l/min	at max rpm l/min			Inlet		Outlet						
						A mm	B mm	M	G	U	M	G	U	
10A(C)1X445	1	1,40	3,26	250	3500	40,1	69,1		1/2" NPTF-14			1/2" NPTF-14		
10A(C)1,25X445	1,25	1,74	4,07	250	3500	40,6	70,1							
10A(C)1,6X445	1,6	2,23	5,21	250	3500	41,3	71,5							
10A(C)2X445	2	2,82	6,58	250	3500	42,1	73,2							
10A(C)2,5X445	2,5	3,53	8,23	250	3500	43,1	75,2							
* 10A(C)2,65X445	2,65	3,74	8,72	250	3500	43,4	75,8							
10A(C)3,15X445	3,15	4,44	10,36	250	3500	44,5	77,8							
10A(C)3,65X445	3,65	5,15	12,01	250	3500	45,4	79,8							
10A(C)4,2X445	4,2	5,92	13,82	250	3500	46,5	82,0							
* 10A(C)4,7X445	4,7	6,63	15,46	250	3500	47,5	84,1							
10A(C)5X445	5	7,05	14,10	250	3000	48,1	85,2							
10A(C)5,7X445	5,7	8,12	16,25	200	3000	49,5	88,0							
10A(C)6,1X445	6,1	8,69	14,49	200	2500	50,4	89,8							
10A(C)7,4X445	7,4	10,55	17,58	180	2500	53,1	95,3							
* 10A(C)8X445	8	11,40	15,20	150	2000	54,4	97,7							
10A(C)8,5X445	8,5	12,11	16,15	150	2000	55,4	99,8							
10A(C)9,8X445	9,8	13,97	18,62	120	2000	58,0	105,0							

* - These pumps - only under a special order

Rotation "A" - (anticlockwise)

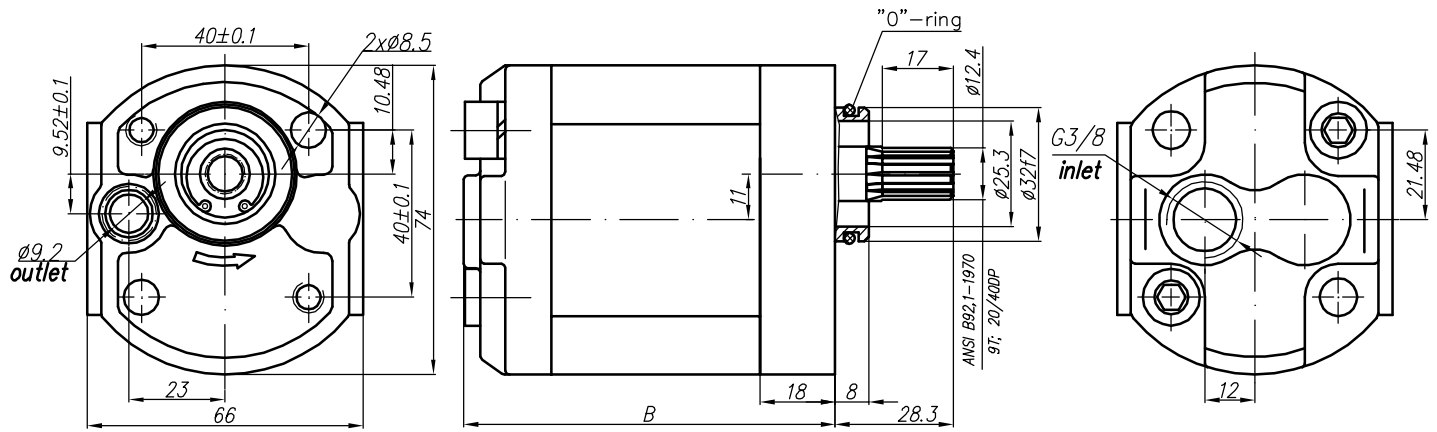

Rotation "C" - (clockwise)

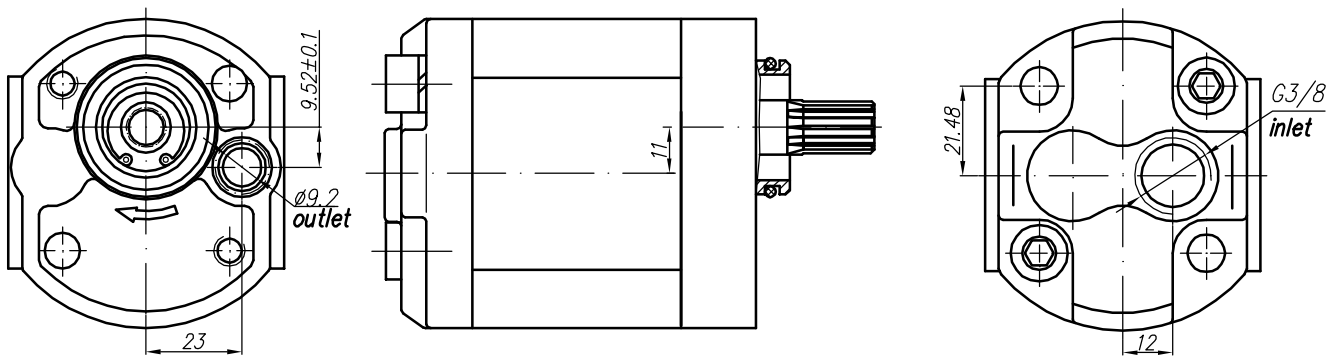

Type	Displacement cm ³ /rev	Flow		Pressure P _{nom} bar	max Speed n rpm	Dimension						
		at 1500 rpm l/min	at max rpm l/min			Inlet			Outlet			
						A mm	B mm	M	G	U		
10A(C)1X459	1	1,40	3,26	250	3500	71	81	G 3/8" - A				ø9,2
10A(C)1,25X459	1,25	1,74	4,07	250	3500	72	82					
10A(C)1,6X459	1,6	2,23	5,21	250	3500	73,6	83,6					
10A(C)2X459	2	2,82	6,58	250	3500	75,2	85,2					
10A(C)2,5X459	2,5	3,53	8,23	250	3500	77,2	87,2					
* 10A(C)2,65X459	2,65	3,74	8,72	250	3500	77,8	87,8					
10A(C)3,15X459	3,15	4,44	10,36	250	3500	79,8	89,8					
10A(C)3,65X459	3,65	5,15	12,01	250	3500	81,9	91,9					
10A(C)4,2X459	4,2	5,92	13,82	250	3500	84,1	94,1					
* 10A(C)4,7X459	4,7	6,63	15,46	250	3500	87,1	97,1					
10A(C)5X459	5	7,05	14,10	250	3000	87,2	97,2					
10A(C)5,7X459	5,7	8,12	16,25	200	3000	90,1	100,1					
10A(C)6,1X459	6,1	8,69	14,49	200	2500	91,8	101,8					
10A(C)7,4X459	7,4	10,55	17,58	180	2500	97,2	107,2					
* 10A(C)8X459	8	11,40	15,20	150	2000	99,7	109,7					
10A(C)8,5X459	8,5	12,11	16,15	150	2000	101,7	111,7					
10A(C)9,8X459	9,8	13,97	18,62	120	2000	107	117					

* - These pumps - only under a special order

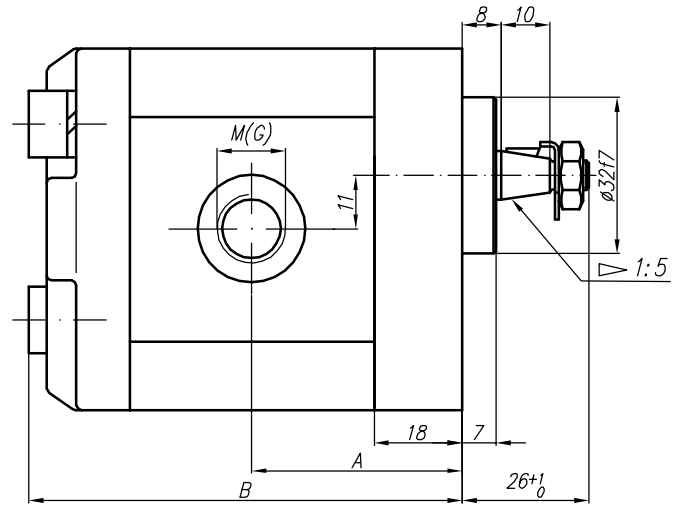
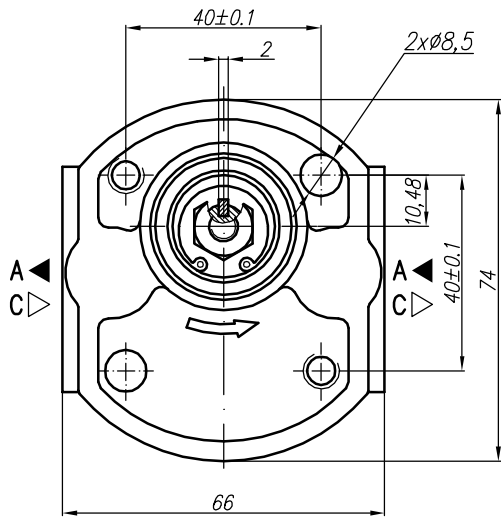

Variants:

...X465M - for M ports (see the table);

...X465G - for G ports (see the table).

Type	Displacement cm ³ /rev	Flow		Pressure P _{nom} bar	max Speed n rpm	Dimension							
		at 1500 rpm l/min	at max rpm l/min			A mm	B mm	Inlet			Outlet		
								M	G	U	M	G	U
10A(C)1X465	1	1,40	3,26	250	3500	39,1	81	M18x1,5	G 3/8" - A		M14x1,5		
10A(C)1,25X465	1,25	1,74	4,07	250	3500	39,5	82						
10A(C)1,6X465	1,6	2,23	5,21	250	3500	40,3	83,6						
10A(C)2X465	2	2,82	6,58	250	3500	41,1	85,2						
10A(C)2,5X465	2,5	3,53	8,23	250	3500	42,1	87,2						
* 10A(C)2,65X465	2,65	3,74	8,72	250	3500	42,4	87,8		G 1/2" - A				
10A(C)3,15X465	3,15	4,44	10,36	250	3500	43,5	89,8						
10A(C)3,65X465	3,65	5,15	12,01	250	3500	44,4	91,9						
10A(C)4,2X465	4,2	5,92	13,82	250	3500	45,5	94,1						
* 10A(C)4,7X465	4,7	6,63	15,46	250	3500	46,1	97,1						
10A(C)5X465	5	7,05	14,10	250	3000	47,1	97,2	M22x1,5					
10A(C)5,7X465	5,7	8,12	16,25	200	3000	48,5	100,1						
10A(C)6,1X465	6,1	8,69	14,49	200	2500	49,4	101,8						
10A(C)7,4X465	7,4	10,55	17,58	180	2500	52,1	107,2						
* 10A(C)8X465	8	11,40	15,20	150	2000	53,4	109,7						
10A(C)8,5X465	8,5	12,11	16,15	150	2000	54,4	111,7	M18x1,5					
10A(C)9,8X465	9,8	13,97	18,62	120	2000	57	117						

* - These pumps - only under a special order

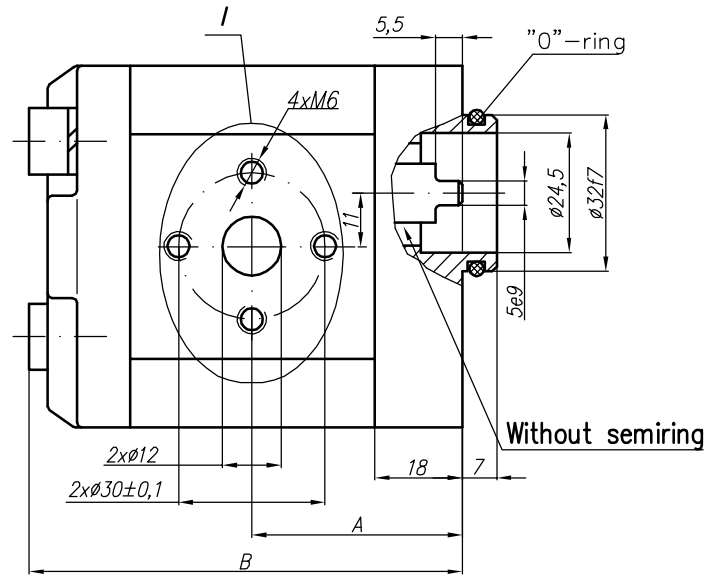
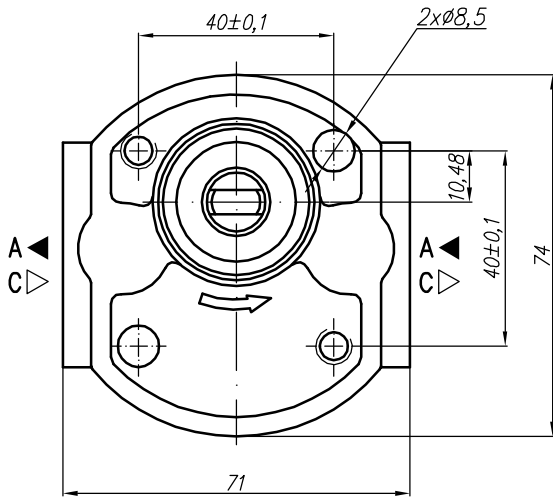

I – variants

Variants:

- ...X475 - Normal version (flange);
- ...X475M - for M ports (see the picture I and the table below);
- ...X475G - for G ports (see the picture I and the table below);
- ...X475U - for U ports (see the picture I and the table below).

Variant M

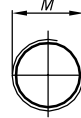

Variant G



Variant U (SAEJ475 (ISO R725))

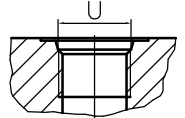
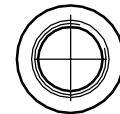

Type	Displacement cm ³ /rev	Flow		Pressure P _{nom} bar	max Speed n rpm	Dimension							
		at 1500 rpm l/min	at max rpm l/min			A mm	B mm	Inlet			Outlet		
								M	G	U	M	G	U
10A(C)1X475	1	1,40	3,26	250	3500	39,1	81	M16x1,5	G 3/8" - A	3/4" - 16UNF - 2B	M16x1,5	G 3/8" - A	9/16" - 18UNF - 2B
10A(C)1,25X475	1,25	1,74	4,07	250	3500	39,5	82						
10A(C)1,6X475	1,6	2,23	5,21	250	3500	40,3	83,6						
10A(C)2X475	2	2,82	6,58	250	3500	41,1	85,2						
10A(C)2,5X475	2,5	3,53	8,23	250	3500	42,1	87,2						
* 10A(C)2,65X475	2,65	3,74	8,72	250	3500	42,4	87,8	M20x1,5	G 1/2" - A	3/4" - 16UNF - 2B	M16x1,5	G 3/8" - A	9/16" - 18UNF - 2B
10A(C)3,15X475	3,15	4,44	10,36	250	3500	43,5	89,8						
10A(C)3,65X475	3,65	5,15	12,01	250	3500	44,4	91,9						
10A(C)4,2X475	4,2	5,92	13,82	250	3500	45,5	94,1						
* 10A(C)4,7X475	4,7	6,63	15,46	250	3500	46,1	97,1						
10A(C)5X475	5	7,05	14,10	250	3000	47,1	97,2	M22x1,5	G 1/2" - A	7/8" - 14UNF	M18x1,5	G 3/8" - A	3/4" - 16UNF
10A(C)5,7X475	5,7	8,12	16,25	200	3000	48,5	100,1						
10A(C)6,1X475	6,1	8,69	14,49	200	2500	49,4	101,8						
10A(C)7,4X475	7,4	10,55	17,58	180	2500	52,1	107,2						
* 10A(C)8X475	8	11,40	15,20	150	2000	53,4	109,7						
10A(C)8,5X475	8,5	12,11	16,15	150	2000	54,4	111,7	M22x1,5	G 1/2" - A	7/8" - 14UNF	M18x1,5	G 3/8" - A	3/4" - 16UNF
10A(C)9,8X475	9,8	13,97	18,62	120	2000	57	117						

* - These pumps - only under a special order

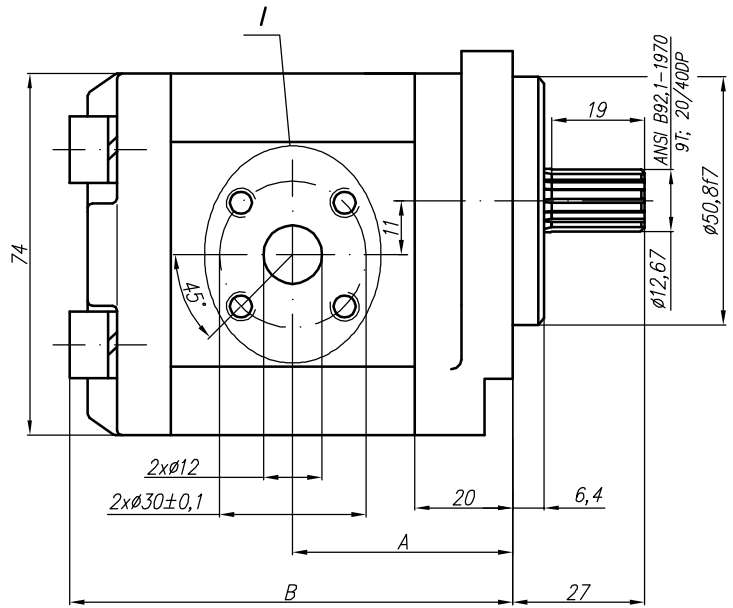
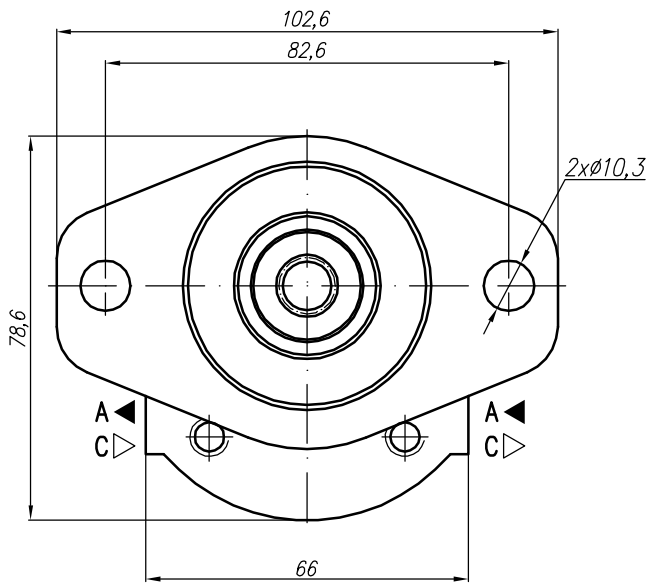

I – variants

Variants:

- ...X476 - Normal version (flange);
- ...X476M - for M ports (see the picture I and the table below);
- ...X476G - for G ports (see the picture I and the table below);
- ...X476U - for U ports (see the picture I and the table below).

Variant M

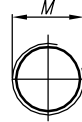

Variant G

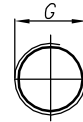

Variant U (SAEJ475 (ISO R725))

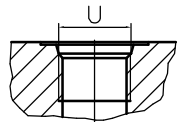

Type	Displacement cm ³ /rev	Flow		Pressure P _{nom} bar	max Speed n rpm	Dimension							
		at 1500 rpm l/min	at max rpm l/min			A mm	B mm	Inlet			Outlet		
								M	G	U	M	G	U
10A(C)1X476	1	1,40	3,26	250	3500	41,1	83	M16x1,5	G 3/8" - A	3/4" - 16UNF - 2B	M16x1,5	G 3/8" - A	9/16" - 18UNF - 2B
10A(C)1,25X476	1,25	1,74	4,07	250	3500	41,5	84						
10A(C)1,6X476	1,6	2,23	5,21	250	3500	42,3	85,6						
10A(C)2X476	2	2,82	6,58	250	3500	43,1	87,2						
10A(C)2,5X476	2,5	3,53	8,23	250	3500	44,1	89,2	M20x1,5	G 1/2" - A	3/4" - 16UNF - 2B	M16x1,5	G 3/8" - A	9/16" - 18UNF - 2B
* 10A(C)2,65X476	2,65	3,74	8,72	250	3500	44,4	89,8						
10A(C)3,15X476	3,15	4,44	10,36	250	3500	45,5	91,8	M22x1,5	G 1/2" - A	7/8" - 14UNF	M18x1,5	G 3/8" - A	3/4" - 16UNF
10A(C)3,65X476	3,65	5,15	12,01	250	3500	46,4	93,9						
10A(C)4,2X476	4,2	5,92	13,82	250	3500	47,5	96,1	M22x1,5	G 1/2" - A	7/8" - 14UNF	M18x1,5	G 3/8" - A	3/4" - 16UNF
* 10A(C)4,7X476	4,7	6,63	15,46	250	3500	48,1	98						
10A(C)5X476	5	7,05	14,10	250	3000	49,1	99,2	M22x1,5	G 1/2" - A	7/8" - 14UNF	M18x1,5	G 3/8" - A	3/4" - 16UNF
10A(C)5,7X476	5,7	8,12	16,25	200	3000	50,5	102,1						
10A(C)6,1X476	6,1	8,69	14,49	200	2500	51,4	103,8	M22x1,5	G 1/2" - A	7/8" - 14UNF	M18x1,5	G 3/8" - A	3/4" - 16UNF
10A(C)7,4X476	7,4	10,55	17,58	180	2500	54,1	109,2						
* 10A(C)8X476	8	11,40	15,20	150	2000	55,4	111,7	M22x1,5	G 1/2" - A	7/8" - 14UNF	M18x1,5	G 3/8" - A	3/4" - 16UNF
10A(C)8,5X476	8,5	12,11	16,15	150	2000	56,4	113,7						
10A(C)9,8X476	9,8	13,97	18,62	120	2000	59	119	M22x1,5	G 1/2" - A	7/8" - 14UNF	M18x1,5	G 3/8" - A	3/4" - 16UNF

* - These pumps - only under a special order

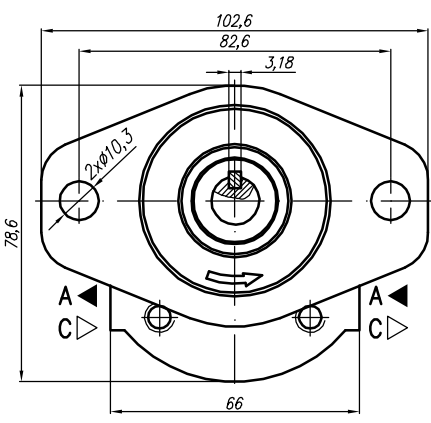

Rotation "A" - (anticlockwise)

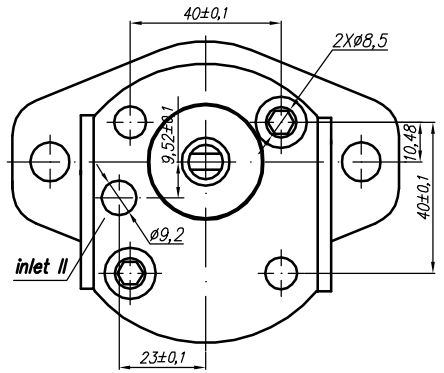
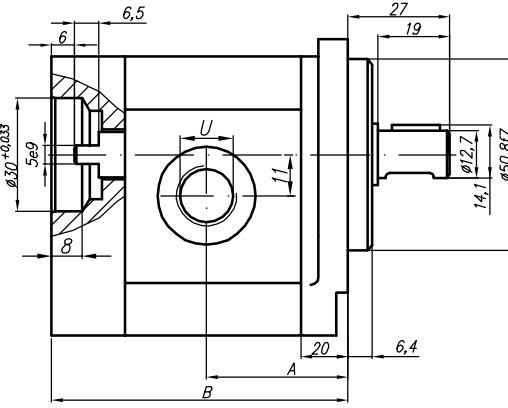

Rotation "C" - (clockwise)

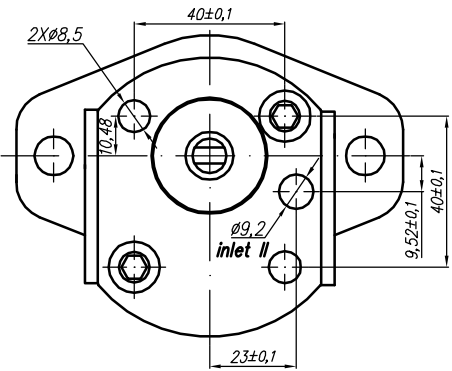
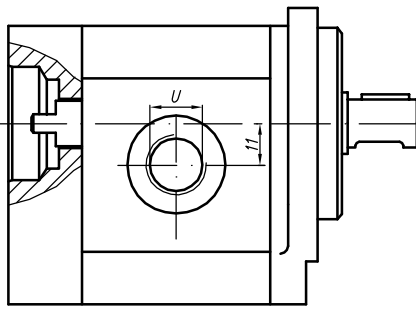
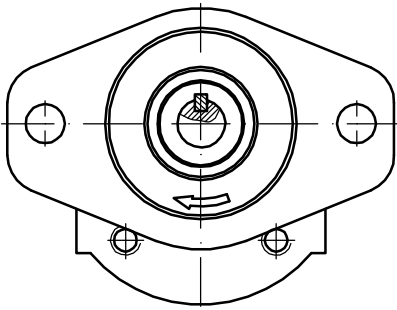

Symbol

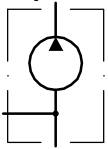

Type	Displacement cm ³ /rev	Flow		Pressure P _{nom} bar	max Speed n rpm	Dimension							
		at 1500 rpm l/min	at max rpm l/min			Inlet			Outlet				
						A mm	B mm	M	G	U	M	G	U
10A(C)1X484	1	1,40	3,26	250	3500	41,1	83						
10A(C)1,25X484	1,25	1,74	4,07	250	3500	41,5	84						
10A(C)1,6X484	1,6	2,23	5,21	250	3500	42,3	85,6						
10A(C)2X484	2	2,82	6,58	250	3500	43,1	87,2						
10A(C)2,5X484	2,5	3,53	8,23	250	3500	44,1	89,2						
* 10A(C)2,65X484	2,65	3,74	8,72	250	3500	44,4	89,8						
10A(C)3,15X484	3,15	4,44	10,36	250	3500	45,5	91,8						
10A(C)3,65X484	3,65	5,15	12,01	250	3500	46,4	93,9						
10A(C)4,2X484	4,2	5,92	13,82	250	3500	47,5	96,1						
* 10A(C)4,7X484	4,7	6,63	15,46	250	3500	48,1	98						
10A(C)5X484	5	7,05	14,10	250	3000	49,1	99,2						
10A(C)5,7X484	5,7	8,12	16,25	200	3000	50,5	102,1						
10A(C)6,1X484	6,1	8,69	14,49	200	2500	51,4	103,8						
10A(C)7,4X484	7,4	10,55	17,58	180	2500	54,1	109,2						
* 10A(C)8X484	8	11,40	15,20	150	2000	55,4	111,7						
10A(C)8,5X484	8,5	12,11	16,15	150	2000	56,4	113,7						
10A(C)9,8X484	9,8	13,97	18,62	120	2000	59	119						

* - These pumps - only under a special order

Rotation "A" - (anticlockwise)

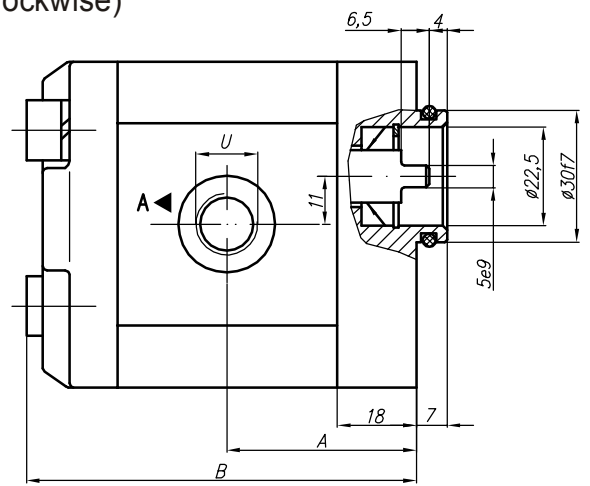
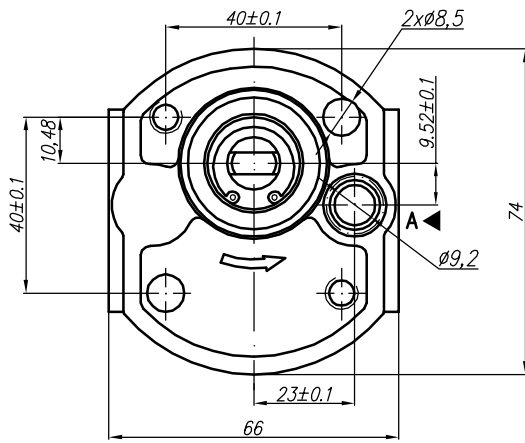

Rotation "C" - (clockwise)

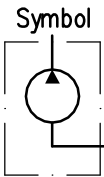
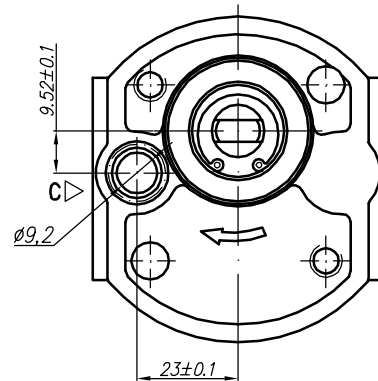
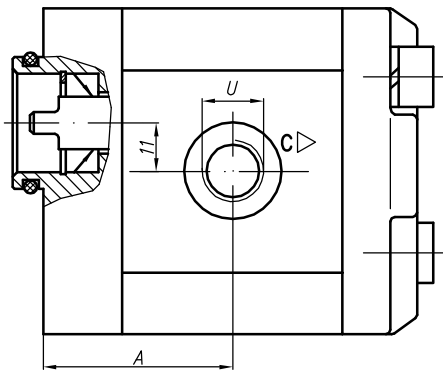

Type	Displacement cm ³ /rev	Flow		Pressure P _{nom} bar	max Speed n rpm	Dimension							
		at 1500 rpm l/min	at max rpm l/min			A mm	B mm	Inlet			Outlet		
											M	G	U
10A(C)1X485	1	1,40	3,26	250	3500	39,1	81						
10A(C)1,25X485	1,25	1,74	4,07	250	3500	39,5	82						
10A(C)1,6X485	1,6	2,23	5,21	250	3500	40,3	83,6						
10A(C)2X485	2	2,82	6,58	250	3500	41,1	85,2						
10A(C)2,5X485	2,5	3,53	8,23	250	3500	42,1	87,2						
* 10A(C)2,65X485	2,65	3,74	8,72	250	3500	42,4	87,8						
10A(C)3,15X485	3,15	4,44	10,36	250	3500	43,5	89,8						
10A(C)3,65X485	3,65	5,15	12,01	250	3500	44,4	91,9						
10A(C)4,2X485	4,2	5,92	13,82	250	3500	45,5	94,1			∅9,2			
* 10A(C)4,7X485	4,7	6,63	15,46	250	3500	46,1	97,1						
10A(C)5X485	5	7,05	14,10	250	3000	47,1	97,2						
10A(C)5,7X485	5,7	8,12	16,25	200	3000	48,5	100,1						
10A(C)6,1X485	6,1	8,69	14,49	200	2500	49,4	101,8						
10A(C)7,4X485	7,4	10,55	17,58	180	2500	52,1	107,2						
* 10A(C)8X485	8	11,40	15,20	150	2000	53,4	109,7						
10A(C)8,5X485	8,5	12,11	16,15	150	2000	54,4	111,7						
10A(C)9,8X485	9,8	13,97	18,62	120	2000	57	117						

* - These pumps - only under a special order

9/16" - 18UNF - 2B

3/4" - 16UNF

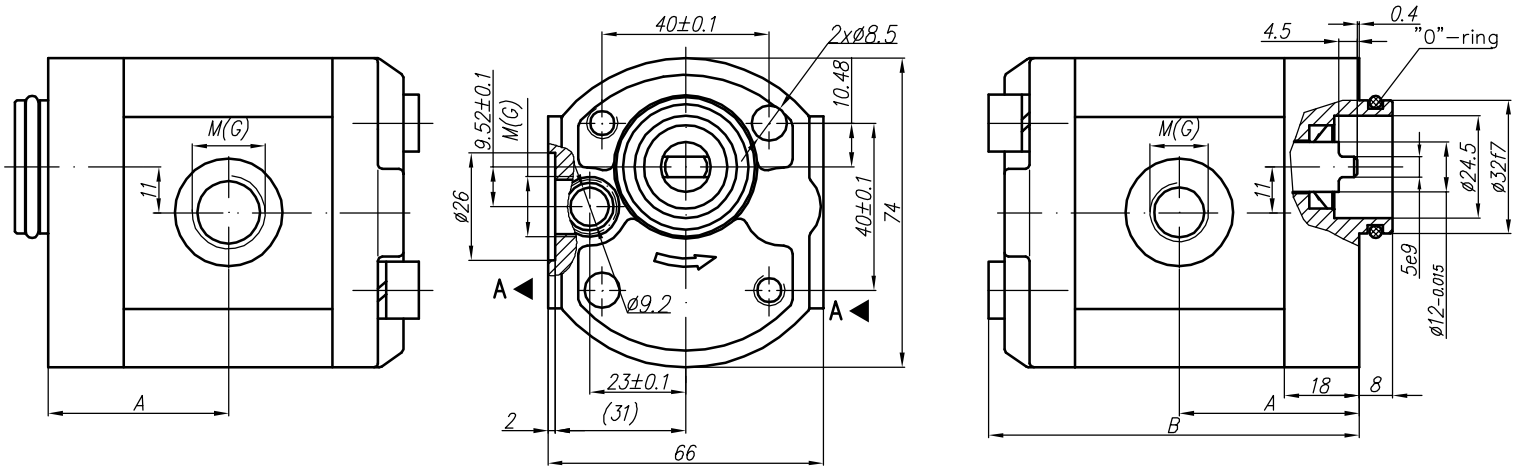

Rotation "C" - (clockwise)

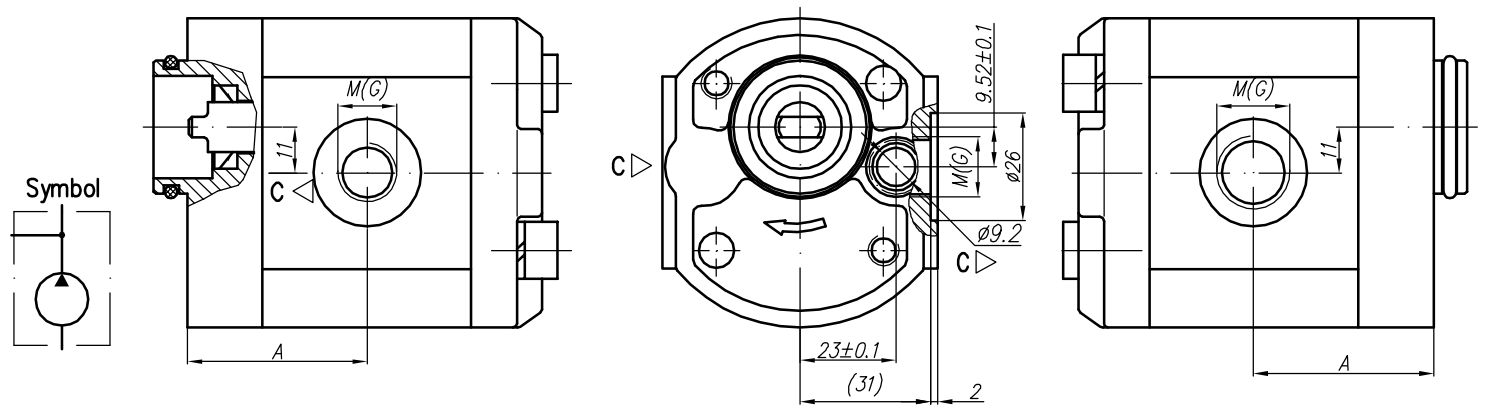

Variants:
 ...X488M - for M ports (see the picture and the table);
 ...X488G - for G ports (see the picture and the table).

Type	Displacement cm ³ /rev	Flow		Pressure P _{nom} bar	max Speed n rpm	Dimension							
		at 1500 rpm l/min	at max rpm l/min			A mm	B mm	Inlet			Outlet		
								M	G	U	M	G	U
10A(C)1X488	1	1,40	3,26	250	3500	39,1	81	M18x1,5	G 3/8" - A				
10A(C)1,25X488	1,25	1,74	4,07	250	3500	39,5	82						
10A(C)1,6X488	1,6	2,23	5,21	250	3500	40,3	83,6						
10A(C)2X488	2	2,82	6,58	250	3500	41,1	85,2						
10A(C)2,5X488	2,5	3,53	8,23	250	3500	42,1	87,2						
* 10A(C)2,65X488	2,65	3,74	8,72	250	3500	42,4	87,8						
10A(C)3,15X488	3,15	4,44	10,36	250	3500	43,5	89,8		G 1/2" - A				
10A(C)3,65X488	3,65	5,15	12,01	250	3500	44,4	91,9						
10A(C)4,2X488	4,2	5,92	13,82	250	3500	45,5	94,1						
* 10A(C)4,7X488	4,7	6,63	15,46	250	3500	46,1	96						
10A(C)5X488	5	7,05	14,10	250	3000	47,1	97,2						
10A(C)5,7X488	5,7	8,12	16,25	200	3000	48,5	100,1	M14x1,5	G 3/8" - A				
10A(C)6,1X488	6,1	8,69	14,49	200	2500	49,4	101,8						
10A(C)7,4X488	7,4	10,55	17,58	180	2500	52,1	107,2						
* 10A(C)8X488	8	11,40	15,20	150	2000	53,4	109,7						
10A(C)8,5X488	8,5	12,11	16,15	150	2000	54,4	111,7						
10A(C)9,8X488	9,8	13,97	18,62	120	2000	57	117						

* - These pumps - only under a special order

Rotation "A" - (anticlockwise)

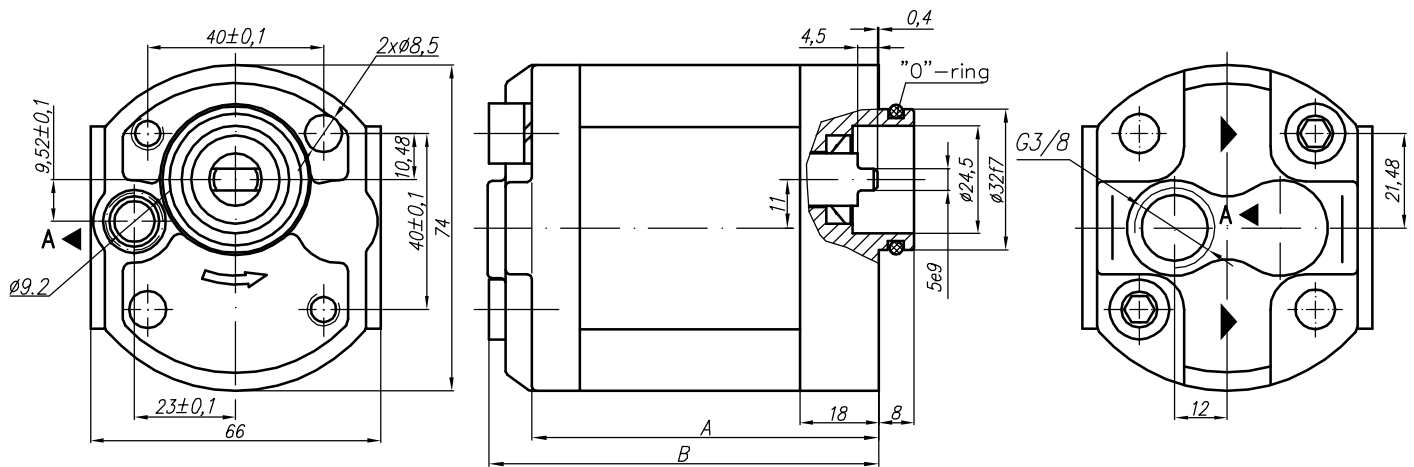

Rotation "C" - (clockwise)

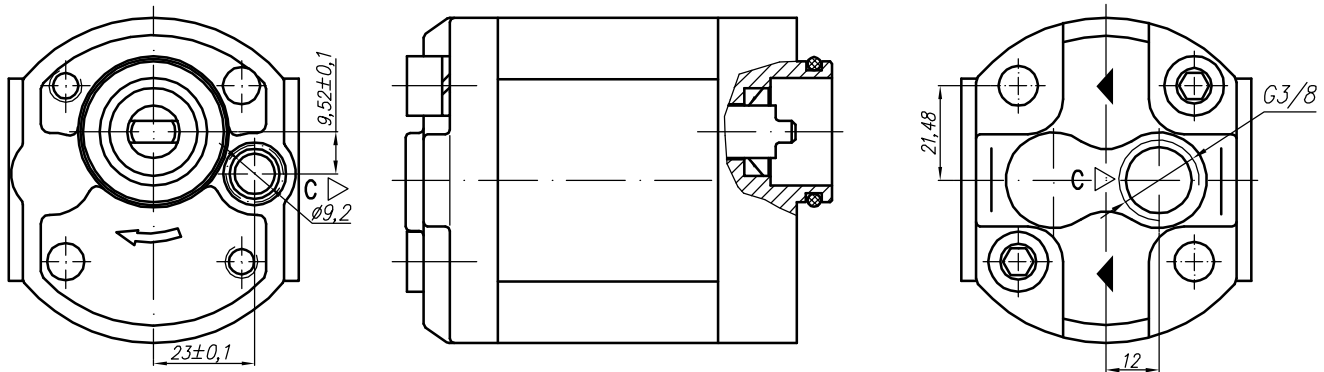

Type	Displacement cm ³ /rev	Flow		Pressure P _{nom} bar	max Speed n rpm	Dimension							
		at 1500 rpm l/min	at max rpm l/min			A mm	B mm	Inlet			Outlet		
10A(C)1X489	1	1,40	3,26	250	3500	71	81	G 3/8" - A	M	G	U	ø9,2	
10A(C)1,25X489	1,25	1,74	4,07	250	3500	72	82						
10A(C)1,6X489	1,6	2,23	5,21	250	3500	73,6	83,6						
10A(C)2X489	2	2,82	6,58	250	3500	75,2	85,2						
10A(C)2,5X489	2,5	3,53	8,23	250	3500	77,2	87,2						
* 10A(C)2,65X489	2,65	3,74	8,72	250	3500	77,8	87,8						
10A(C)3,15X489	3,15	4,44	10,36	250	3500	79,8	89,8						
10A(C)3,65X489	3,65	5,15	12,01	250	3500	81,9	91,9						
10A(C)4,2X489	4,2	5,92	13,82	250	3500	84,1	94,1						
* 10A(C)4,7X489	4,7	6,63	15,46	250	3500	87,1	97,1						
10A(C)5X489	5	7,05	14,10	250	3000	87,2	97,2						
10A(C)5,7X489	5,7	8,12	16,25	200	3000	90,1	100,1						
10A(C)6,1X489	6,1	8,69	14,49	200	2500	91,8	101,8						
10A(C)7,4X489	7,4	10,55	17,58	180	2500	97,2	107,2						
* 10A(C)8X489	8	11,40	15,20	150	2000	99,7	109,7						
10A(C)8,5X489	8,5	12,11	16,15	150	2000	101,7	111,7						
10A(C)9,8X489	9,8	13,97	18,62	120	2000	107	117						

* - These pumps - only under a special order

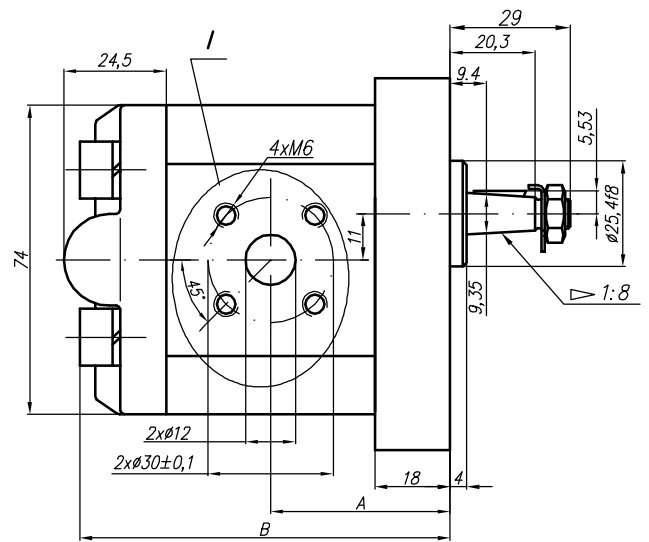
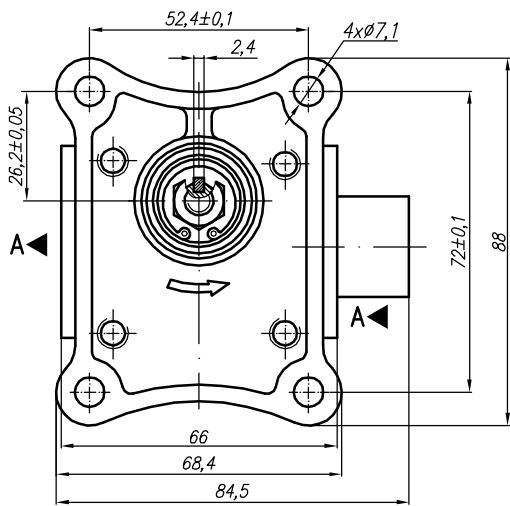
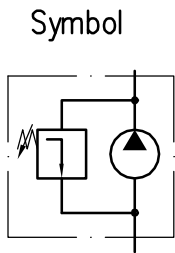

Rotation "C" - (clockwise)

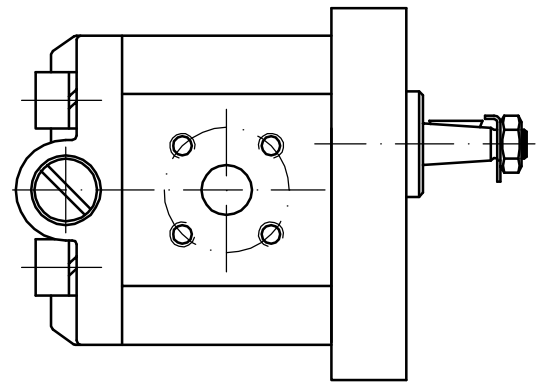
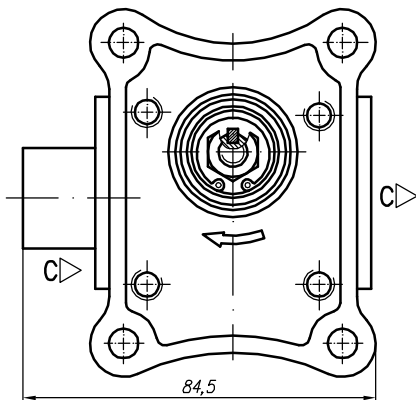

I - variants

Pump variants:

- ...X491 - Normal version (flange);
- ...X491M - for M ports (see the picture I and the table below);
- ...X491G - for G ports (see the picture I and the table below);
- ...X491U - for U ports (see the picture I and the table below).

Variant M

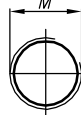

Variant G

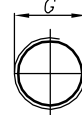

Variant U (SAEJ475 (ISO R725))

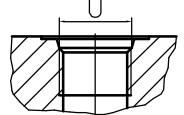
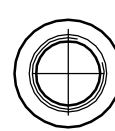

Valve variants:

- A2A1 - pressure range 70 ... 180 bar;
- A2A2 - pressure range 40 ... 100 bar;
- A2A4 - pressure range 15 ... 50 bar.

Type	Displacement cm ³ /rev	Flow		Pressure bar	max Speed n rpm	Dimension							
		at 1500 rpm l/min	at max rpm l/min			Inlet			Outlet				
						A mm	B mm	M	G	U	M	G	U
10A(C)1X491/A2A...	1	1,40	3,26	A2A1 - 70...180 A2A2 - 40...100 A2A4 - 15...50	3500	41,1	83	M16x1,5	G 3/8" - A	3/4" - 16UNF - 2B	M16x1,5	G 3/8" - A	9/16" - 18UNF - 2B
10A(C)1,25X491/A2A...	1,25	1,74	4,07		3500	41,5	84						
10A(C)1,6X491/A2A...	1,6	2,23	5,21		3500	42,3	85,6						
10A(C)2X491/A2A...	2	2,82	6,58		3500	43,1	87,2	M20x1,5	G 1/2" - A				
10A(C)2,5X491/A2A...	2,5	3,53	8,23		3500	44,1	89,2						
10A(C)3,15X491/A2A...	3,15	4,44	10,36		3500	45,5	91,8	M20x1,5	G 1/2" - A				
10A(C)3,65X491/A2A...	3,65	5,15	12,01		3500	46,4	93,9						
10A(C)4,2X491/A2A...	4,2	5,92	13,82		3500	47,5	96,1	M20x1,5	G 1/2" - A				
10A(C)5X491/A2A...	5	7,05	16,45		3500	49,1	99,2						
10A(C)5,7X491/A2A...	5,7	8,12	16,25		3000	50,5	102	M20x1,5	G 1/2" - A				
10A(C)6,1X491/A2A...	6,1	8,69	14,49	2500	51,4	103,8							

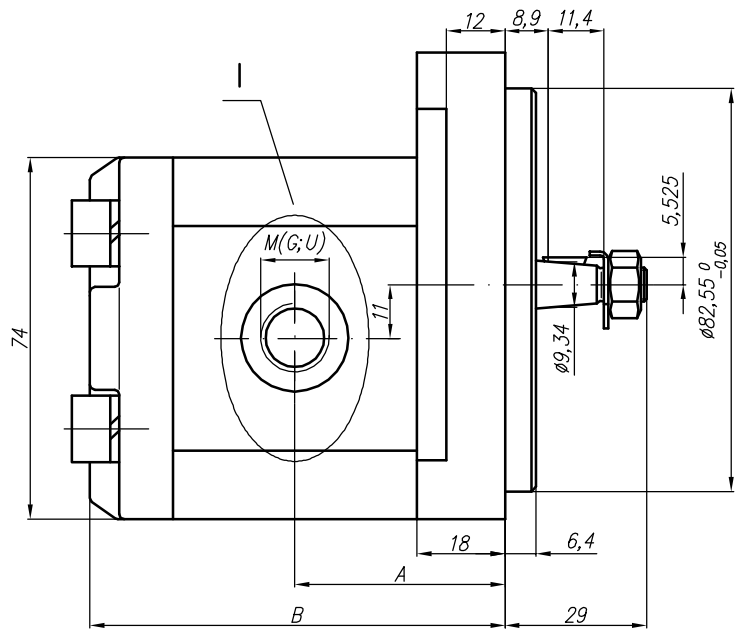
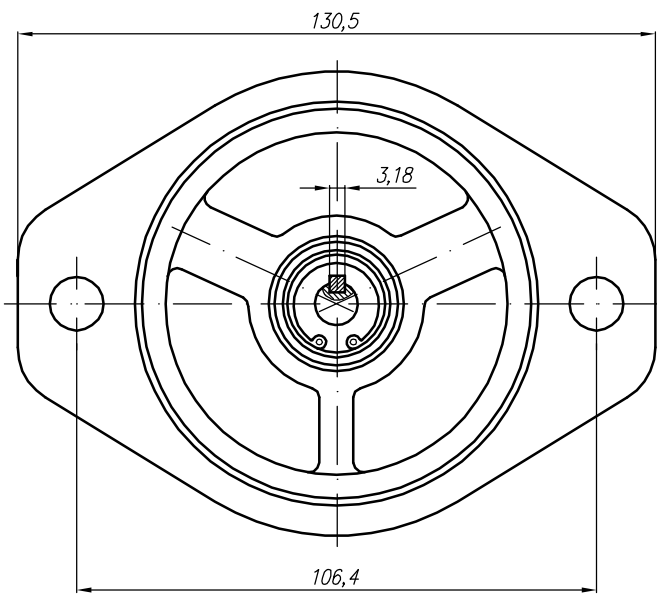

Variants:

- ...X501M - for M ports (see the picture I and the table below);
- ...X501G - for G ports (see the picture I and the table below);
- ...X501U - for U ports (see the picture I and the table below).

I – variants

Variant M

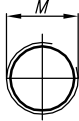

Variant G

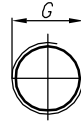

Variant U (SAEJ475 (ISO R725))

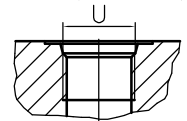
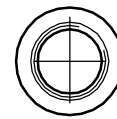

Type	Displacement cm ³ /rev	Flow		Pressure P _{nom} bar	max Speed n rpm	Dimension							
		at 1500 rpm l/min	at max rpm l/min			A mm	B mm	Inlet			Outlet		
10A(C)1X501	1	1,40	3,26	250	3500	39,1	81	M16x1,5	G 3/8" - A	3/4" - 16UNF - 2B	M16x1,5	G 3/8" - A	9/16" - 18UNF - 2B
10A(C)1,25X501	1,25	1,74	4,07	250	3500	39,5	82						
10A(C)1,6X501	1,6	2,23	5,21	250	3500	40,3	83,6						
10A(C)2X501	2	2,82	6,58	250	3500	41,1	85,2						
10A(C)2,5X501	2,5	3,53	8,23	250	3500	42,1	87,2						
* 10A(C)2,65X501	2,65	3,74	8,72	250	3500	42,4	87,8	M20x1,5	G 1/2" - A	3/4" - 16UNF - 2B	M16x1,5	G 3/8" - A	9/16" - 18UNF - 2B
10A(C)3,15X501	3,15	4,44	10,36	250	3500	43,5	89,8						
10A(C)3,65X501	3,65	5,15	12,01	250	3500	44,4	91,9	M20x1,5	G 1/2" - A	3/4" - 16UNF - 2B	M16x1,5	G 3/8" - A	9/16" - 18UNF - 2B
10A(C)4,2X501	4,2	5,92	13,82	250	3500	45,5	94,1						
* 10A(C)4,7X501	4,7	6,63	15,46	250	3500	46,1	97,1	M20x1,5	G 1/2" - A	3/4" - 16UNF - 2B	M16x1,5	G 3/8" - A	9/16" - 18UNF - 2B
10A(C)5X501	5	7,05	14,10	250	3000	47,1	97,2						
10A(C)5,7X501	5,7	8,12	16,25	200	3000	48,5	100,1	M20x1,5	G 1/2" - A	3/4" - 16UNF - 2B	M16x1,5	G 3/8" - A	9/16" - 18UNF - 2B
10A(C)6,1X501	6,1	8,69	14,49	200	2500	49,4	101,8						

* - These pumps - only under a special order

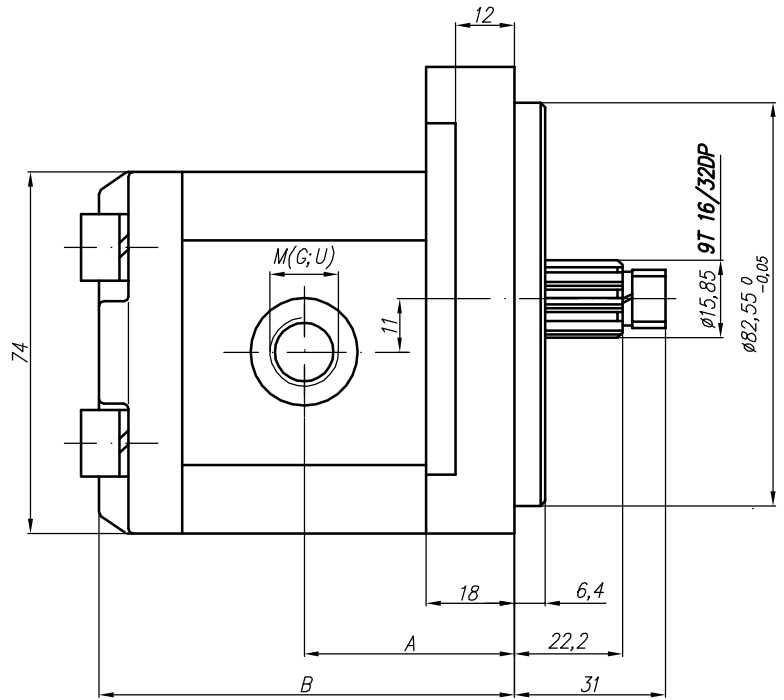
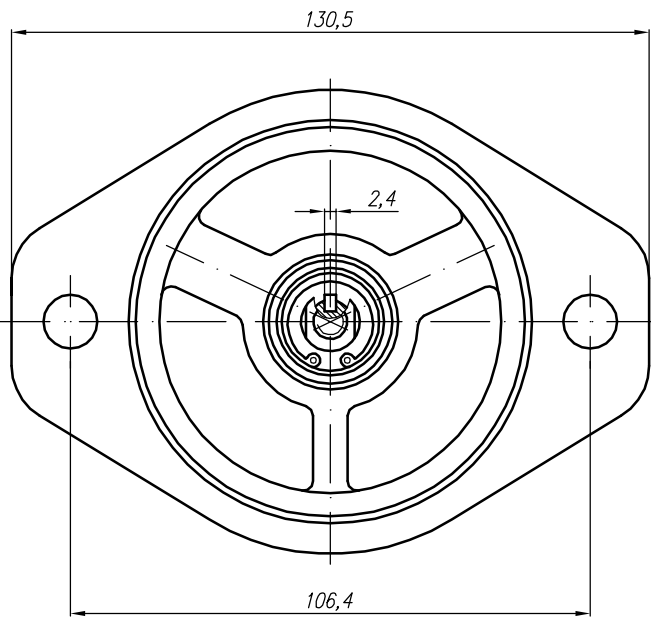

Variants:

...X502M - for M ports (see the picture I and the table below);

...X502G - for G ports (see the picture I and the table below);

...X502U - for U ports (see the picture I and the table below).

I – variants

Variant M

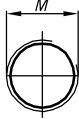

Variant G

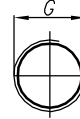

Variant U (SAEJ475 (ISO R725))

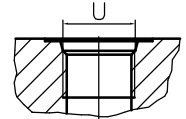
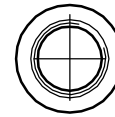

Type	Displacement cm ³ /rev	Flow		Pressure P _{nom} bar	max Speed n rpm	Dimension							
		at 1500 rpm l/min	at max rpm l/min			A mm	B mm	Inlet			Outlet		
								M	G	U	M	G	U
10A(C)1X502	1	1,40	3,26	250	3500	39,1	81	M16x1,5	G 3/8" - A	3/4" - 16UNF - 2B	M16x1,5	G 3/8" - A	9/16" - 18UNF - 2B
10A(C)1,25X502	1,25	1,74	4,07	250	3500	39,5	82						
10A(C)1,6X502	1,6	2,23	5,21	250	3500	40,3	83,6						
10A(C)2X502	2	2,82	6,58	250	3500	41,1	85,2						
10A(C)2,5X502	2,5	3,53	8,23	250	3500	42,1	87,2						
* 10A(C)2,65X502	2,65	3,74	8,72	250	3500	42,4	87,8	M20x1,5	G 1/2" - A	3/4" - 16UNF - 2B	M16x1,5	G 3/8" - A	9/16" - 18UNF - 2B
10A(C)3,15X502	3,15	4,44	10,36	250	3500	43,5	89,8						
10A(C)3,65X502	3,65	5,15	12,01	250	3500	44,4	91,9	M20x1,5	G 1/2" - A	3/4" - 16UNF - 2B	M16x1,5	G 3/8" - A	9/16" - 18UNF - 2B
10A(C)4,2X502	4,2	5,92	13,82	250	3500	45,5	94,1						
* 10A(C)4,7X502	4,7	6,63	15,46	250	3500	46,1	97,1	M20x1,5	G 1/2" - A	3/4" - 16UNF - 2B	M16x1,5	G 3/8" - A	9/16" - 18UNF - 2B
10A(C)5X502	5	7,05	14,10	250	3000	47,1	97,2						
10A(C)5,7X502	5,7	8,12	16,25	200	3000	48,5	100,1	M20x1,5	G 1/2" - A	3/4" - 16UNF - 2B	M16x1,5	G 3/8" - A	9/16" - 18UNF - 2B
10A(C)6,1X502	6,1	8,69	14,49	200	2500	49,4	101,8						

* - These pumps - only under a special order

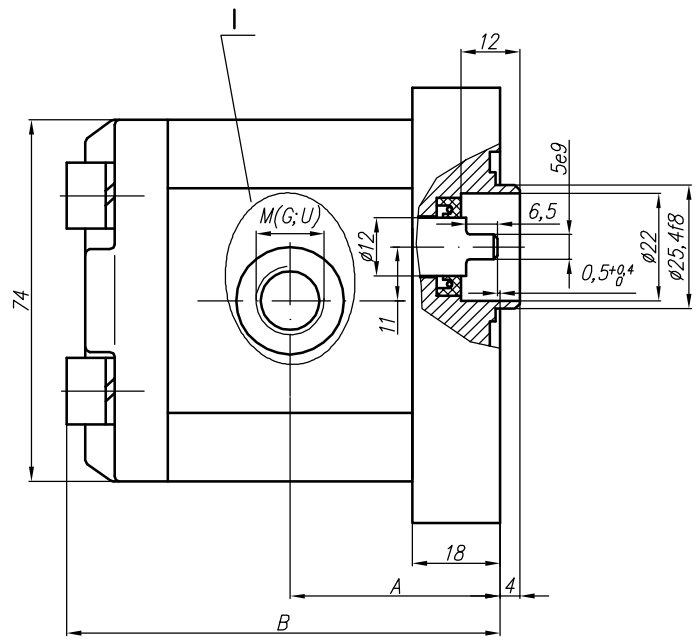
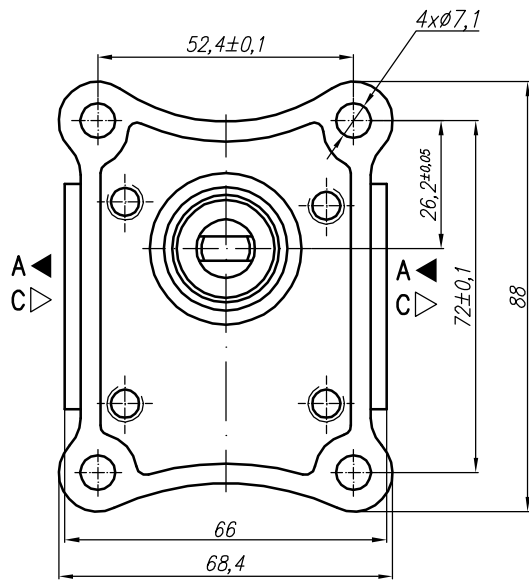

Variants:

- ...X510M - for M ports (see the picture I and the table below);
- ...X510G - for G ports (see the picture I and the table below);
- ...X510U - for U ports (see the picture I and the table below).

I – variants

Variant M

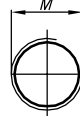

Variant G

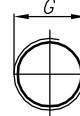

Variant U (SAEJ475 (ISO R725))

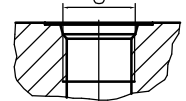
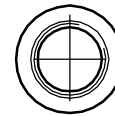

Type	Displacement cm ³ /rev	Flow		Pressure P _{nom} bar	max Speed n rpm	Dimension							
		at 1500 rpm l/min	at max rpm l/min			Inlet		Outlet					
						A mm	B mm	M	G	U	M	G	U
10A(C)1X510	1	1,40	3,26	250	3500	39,1	81	M16x1,5	G 3/8" - A	3/4" - 16UNF - 2B	M16x1,5	G 3/8" - A	9/16" - 18UNF - 2B
10A(C)1,25X510	1,25	1,74	4,07	250	3500	39,5	82						
10A(C)1,6X510	1,6	2,23	5,21	250	3500	40,3	83,6						
10A(C)2X510	2	2,82	6,58	250	3500	41,1	85,2						
10A(C)2,5X510	2,5	3,53	8,23	250	3500	42,1	87,2	M20x1,5	G 1/2" - A	3/4" - 16UNF - 2B	M16x1,5	G 3/8" - A	9/16" - 18UNF - 2B
* 10A(C)2,65X510	2,65	3,74	8,72	250	3500	42,4	87,8						
10A(C)3,15X510	3,15	4,44	10,36	250	3500	43,5	89,8	M20x1,5	G 1/2" - A	3/4" - 16UNF - 2B	M16x1,5	G 3/8" - A	9/16" - 18UNF - 2B
10A(C)3,65X510	3,65	5,15	12,01	250	3500	44,4	91,9						
10A(C)4,2X510	4,2	5,92	13,82	250	3500	45,5	94,1	M22x1,5	G 1/2" - A	3/4" - 16UNF - 2B	M18x1,5	G 3/8" - A	9/16" - 18UNF - 2B
* 10A(C)4,7X510	4,7	6,63	15,46	250	3500	46,1	97,1						
10A(C)5X510	5	7,05	14,10	250	3000	47,1	97,2	M22x1,5	G 1/2" - A	7/8" - 14UNF	M18x1,5	G 3/8" - A	3/4" - 16UNF
10A(C)5,7X510	5,7	8,12	16,25	200	3000	48,5	100,1						
10A(C)6,1X510	6,1	8,69	14,49	200	2500	49,4	101,8	M22x1,5	G 1/2" - A	7/8" - 14UNF	M18x1,5	G 3/8" - A	3/4" - 16UNF
10A(C)7,4X510	7,4	10,55	17,58	180	2500	52,1	107,2						
* 10A(C)8X510	8	11,40	15,20	150	2000	53,4	109,7	M22x1,5	G 1/2" - A	7/8" - 14UNF	M18x1,5	G 3/8" - A	3/4" - 16UNF
10A(C)8,5X510	8,5	12,11	16,15	150	2000	54,4	111,7						
10A(C)9,8X510	9,8	13,97	18,62	120	2000	57	117	M22x1,5	G 1/2" - A	7/8" - 14UNF	M18x1,5	G 3/8" - A	3/4" - 16UNF

* - These pumps - only under a special order

Rotation "A" - (anticlockwise)

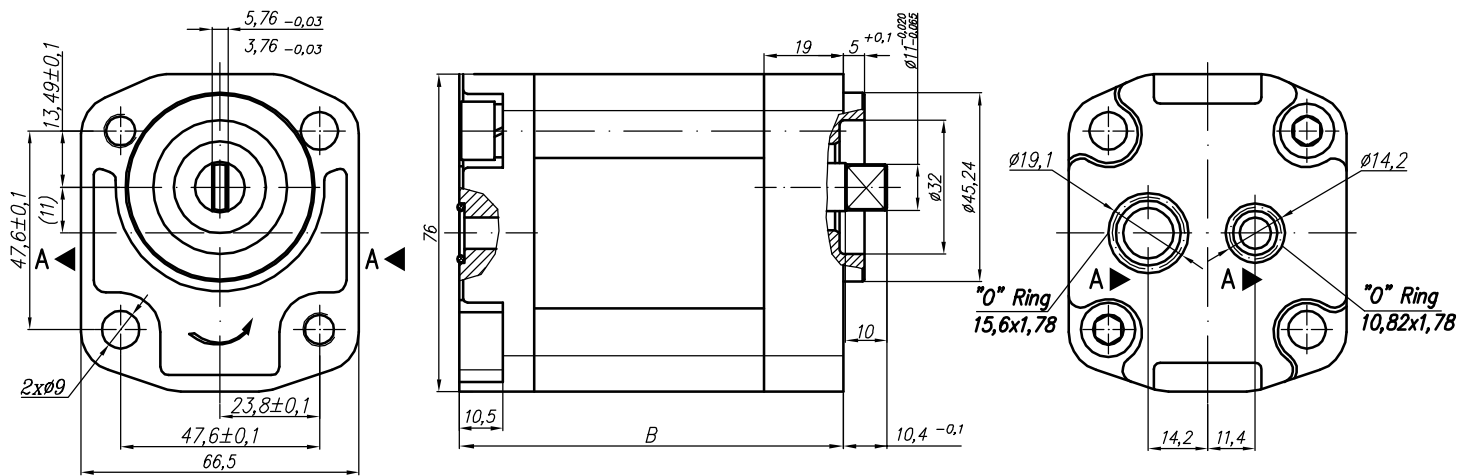

Rotation "C" - (clockwise)

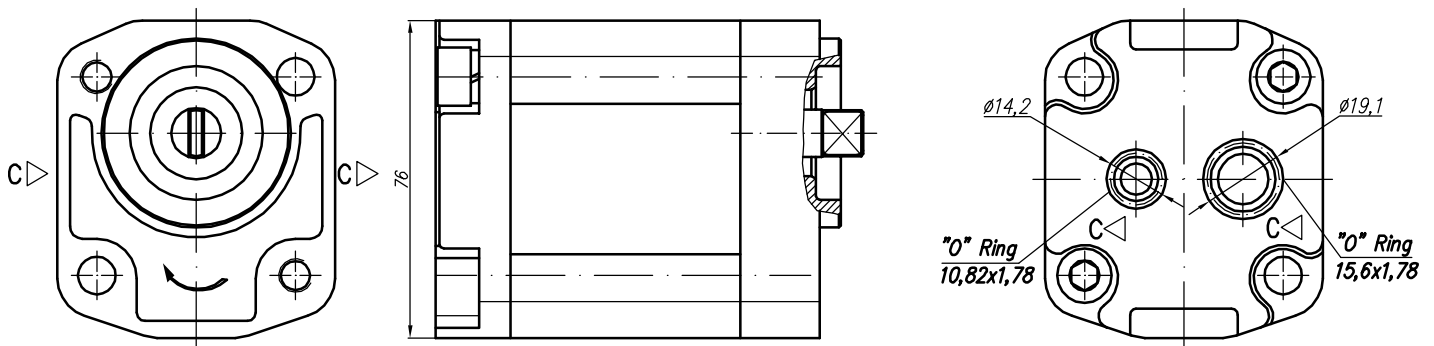

Variants:

- for drive shaft 3,76 - ...531-3

Type	Displacement cm ³ /rev	Flow		Pressure P _{nom} bar	max Speed n rpm	Dimension							
		at 1500 rpm l/min	at max rpm l/min			A mm	B mm	Inlet		Outlet			
10A(C)1X531	1	1,40	3,26	250	3500		78,2						
10A(C)1,25X531	1,25	1,74	4,07	250	3500		79,2						
10A(C)1,6X531	1,6	2,23	5,21	250	3500		80,6						
10A(C)2X531	2	2,82	6,58	250	3500		82,2						
10A(C)2,5X531	2,5	3,53	8,23	250	3500		84,2						
10A(C)3,15X531	3,15	4,44	10,36	250	3500		87						
10A(C)3,65X531	3,65	5,15	12,01	250	3500		89,6						
10A(C)4,2X531	4,2	5,92	13,82	250	3500		90,3						
10A(C)5X531	5	7,05	14,10	250	3000		94,9						
10A(C)5,7X531	5,7	8,12	16,25	200	3000		97,8						
10A(C)6,1X531	6,1	8,69	14,49	200	2500		100,8						

Rotation "A" - (anticlockwise)

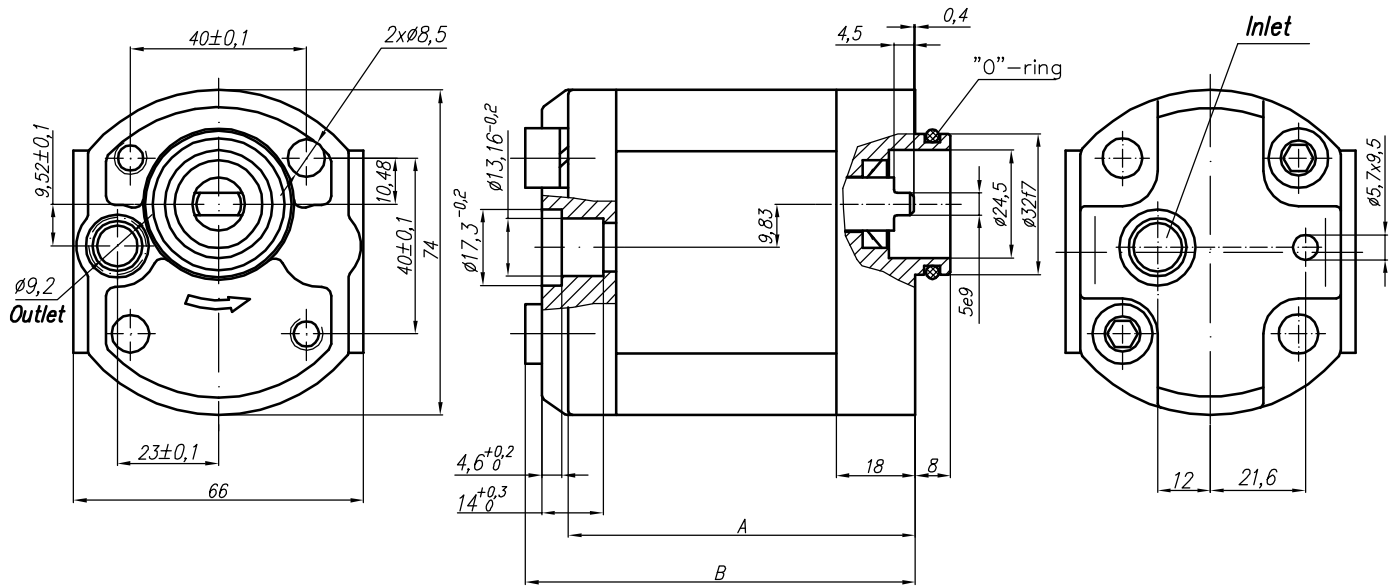

Type	Displacement cm ³ /rev	Flow		Pressure P _{nom} bar	max Speed n rpm	Dimension							
		at 1500 rpm l/min	at max rpm l/min			A mm	B mm	Inlet		Outlet			
10A1X552	1	1,40	3,26	250	3500	71	81						
10A1,25X552	1,25	1,74	4,07	250	3500	72	82						
10A1,6X552	1,6	2,23	5,21	250	3500	73,6	83,6						
10A2X552	2	2,82	6,58	250	3500	75,2	85,2						
10A2,5X552	2,5	3,53	8,23	250	3500	77,2	87,2						
* 10A2,65X552	2,65	3,74	8,72	250	3500	77,8	87,8						
10A3,15X552	3,15	4,44	10,36	250	3500	79,8	89,8						
10A3,65X552	3,65	5,15	12,01	250	3500	81,9	91,9						
10A4,2X552	4,2	5,92	13,82	250	3500	84,1	94,1						ø9,2
* 10A4,7X552	4,7	6,63	15,46	250	3500	87,1	97,1						
10A5X552	5	7,05	14,10	250	3000	87,2	97,2						
10A5,7X552	5,7	8,12	16,25	200	3000	90,1	100,1						
10A6,1X552	6,1	8,69	14,49	200	2500	91,8	101,8						
10A7,4X552	7,4	10,55	17,58	180	2500	97,2	107,2						
* 10A8X552	8	11,40	15,20	150	2000	99,7	109,7						
10A8,5X552	8,5	12,11	16,15	150	2000	101,7	111,7						
10A9,8X552	9,8	13,97	18,62	120	2000	107	117						

* - These pumps - only under a special order

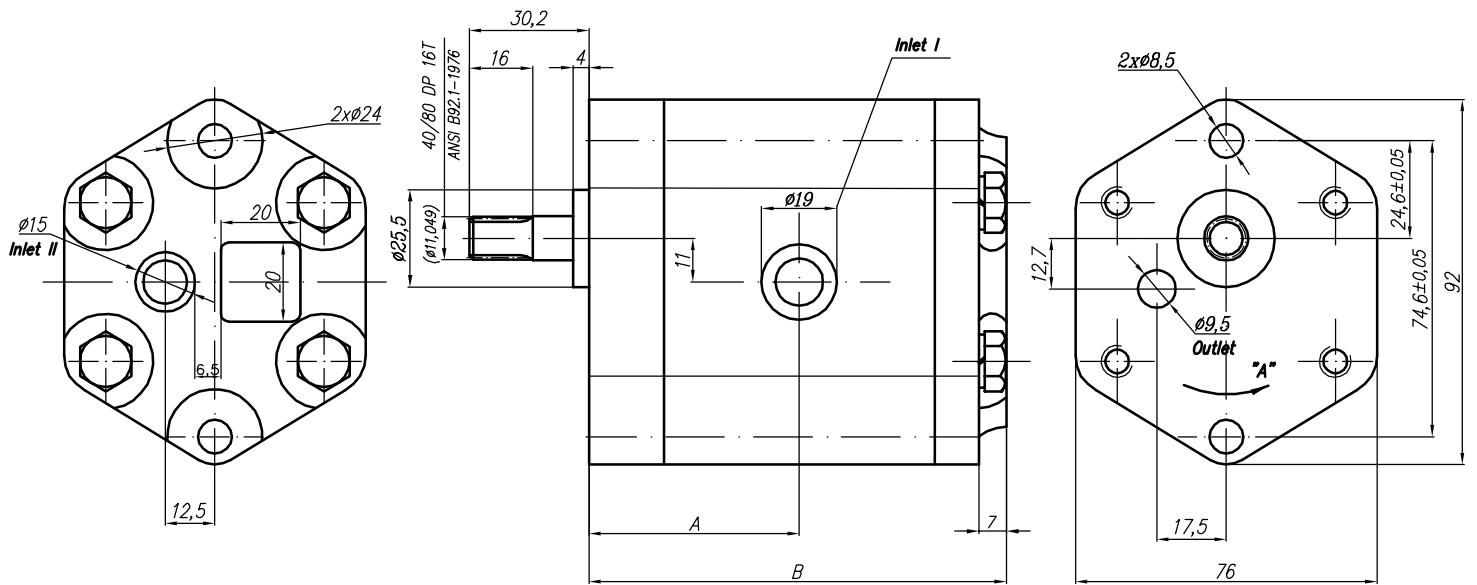

Type	Displacement cm ³ /rev	Flow		Pressure P _{nom} bar	max Speed n rpm	Dimension							
		at 1500 rpm l/min	at max rpm l/min			A mm	B mm	Inlet		Outlet			
10A(C)1X571	1	1,40	3,26	250	3500	40,1	79,1						
10A(C)1,25X571	1,25	1,74	4,07	250	3500	40,6	80,1						
10A(C)1,6X571	1,6	2,23	5,21	250	3500	41,3	81,5						
10A(C)2X571	2	2,82	6,58	250	3500	42,1	83,2						
10A(C)2,5X571	2,5	3,53	8,23	250	3500	43,1	85,2						
* 10A(C)2,65X571	2,65	3,74	8,72	250	3500	43,4	85,8						
10A(C)3,15X571	3,15	4,44	10,36	250	3500	44,5	87,8						
10A(C)3,65X571	3,65	5,15	12,01	250	3500	45,4	89,8						
10A(C)4,2X571	4,2	5,92	13,82	250	3500	46,2	92	$\phi 19$	$\phi 15$			$\phi 9,5$	
* 10A(C)4,7X571	4,7	6,63	15,46	250	3500	47,5	94,1						
10A(C)5X571	5	7,05	14,10	250	3000	48,1	95,2						
10A(C)5,7X571	5,7	8,12	16,25	200	3000	49,5	98						
10A(C)6,1X571	6,1	8,69	14,49	200	2500	50,3	99,8						
10A(C)7,4X571	7,4	10,55	17,58	180	2500	53,1	105,2						
* 10A(C)8X571	8	11,40	15,20	150	2000	54,4	107,7						
10A(C)8,5X571	8,5	12,11	16,15	150	2000	55,4	109,8						
10A(C)9,8X571	9,8	13,97	18,62	120	2000	58	115						

* - These pumps - only under a special order

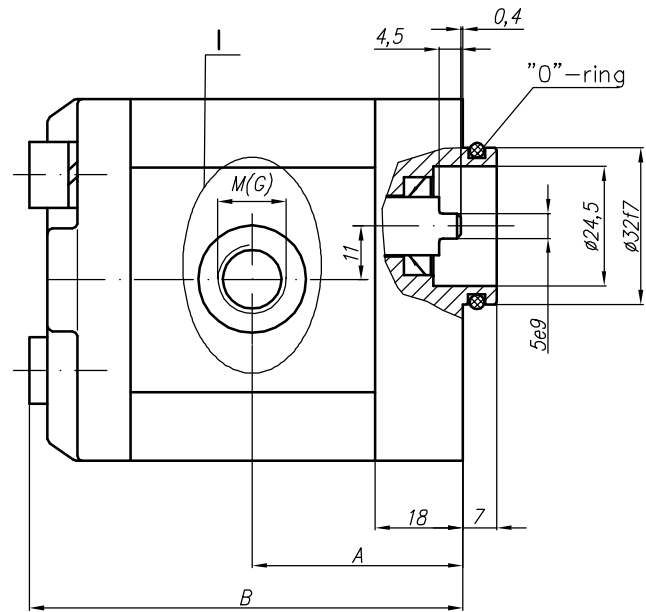
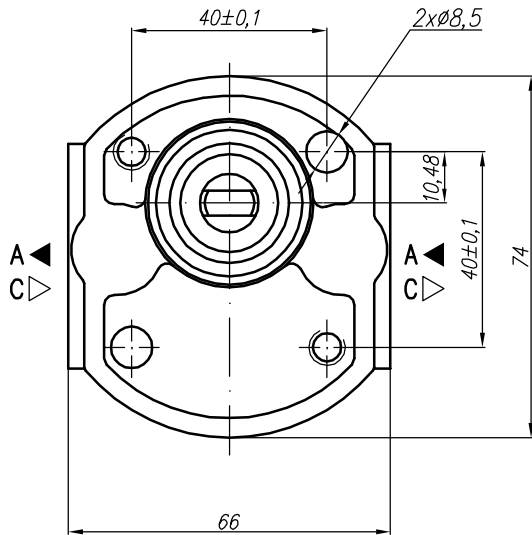

Variants:

...X575M - for M ports (see the picture I and the table below);

...X575G - for G ports (see the picture I and the table below);

...X575U - for U ports (see the picture I and the table below).

I – variants

Variant M

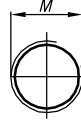

Variant G

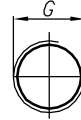

Variant U (SAEJ475 (ISO R725))

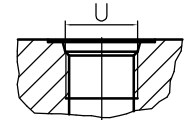

Type	Displacement cm ³ /rev	Flow		Pressure P _{nom} bar	max Speed n rpm	Dimension							
		at 1500 rpm l/min	at max rpm l/min			A mm	B mm	Inlet			Outlet		
								M	G	U	M	G	U
10A(C)1X575	1	1,40	3,26	250	3500	39,1	81	M16x1,5	G 3/8" - A	3/4" - 16UNF - 2B	M16x1,5	G 3/8" - A	9/16" - 18UNF - 2B
10A(C)1,25X575	1,25	1,74	4,07	250	3500	39,5	82						
10A(C)1,6X575	1,6	2,23	5,21	250	3500	40,3	83,6						
10A(C)2X575	2	2,82	6,58	250	3500	41,1	85,2						
10A(C)2,5X575	2,5	3,53	8,23	250	3500	42,1	87,2						
* 10A(C)2,65X575	2,65	3,74	8,72	250	3500	42,4	87,8	M20x1,5	G 1/2" - A	3/4" - 16UNF - 2B	M16x1,5	G 3/8" - A	9/16" - 18UNF - 2B
10A(C)3,15X575	3,15	4,44	10,36	250	3500	43,5	89,8						
10A(C)3,65X575	3,65	5,15	12,01	250	3500	44,4	91,9	M20x1,5	G 1/2" - A	3/4" - 16UNF - 2B	M16x1,5	G 3/8" - A	9/16" - 18UNF - 2B
10A(C)4,2X575	4,2	5,92	13,82	250	3500	45,5	94,1						
* 10A(C)4,7X575	4,7	6,63	15,46	250	3500	46,1	96						
10A(C)5X575	5	7,05	14,10	250	3000	47,1	97,2	M22x1,5	G 1/2" - A	7/8" - 14UNF	M18x1,5	G 3/8" - A	3/4" - 16UNF
10A(C)5,7X575	5,7	8,12	16,25	200	3000	48,5	100,1						
10A(C)6,1X575	6,1	8,69	14,49	200	2500	49,4	101,8	M22x1,5	G 1/2" - A	7/8" - 14UNF	M18x1,5	G 3/8" - A	3/4" - 16UNF
10A(C)7,4X575	7,4	10,55	17,58	180	2500	52,1	107,2						
10A(C)8X575	8	11,40	15,20	150	2000	53,4	109,7	M22x1,5	G 1/2" - A	7/8" - 14UNF	M18x1,5	G 3/8" - A	3/4" - 16UNF
10A(C)8,5X575	8,5	12,11	16,15	150	2000	54,4	111,7						
10A(C)9,8X575	9,8	13,97	18,62	120	2000	57	117	M22x1,5	G 1/2" - A	7/8" - 14UNF	M18x1,5	G 3/8" - A	3/4" - 16UNF

* - These pumps - only under a special order

The pump 10A(C)...X576 is a first section of multiple pump Gr.11.

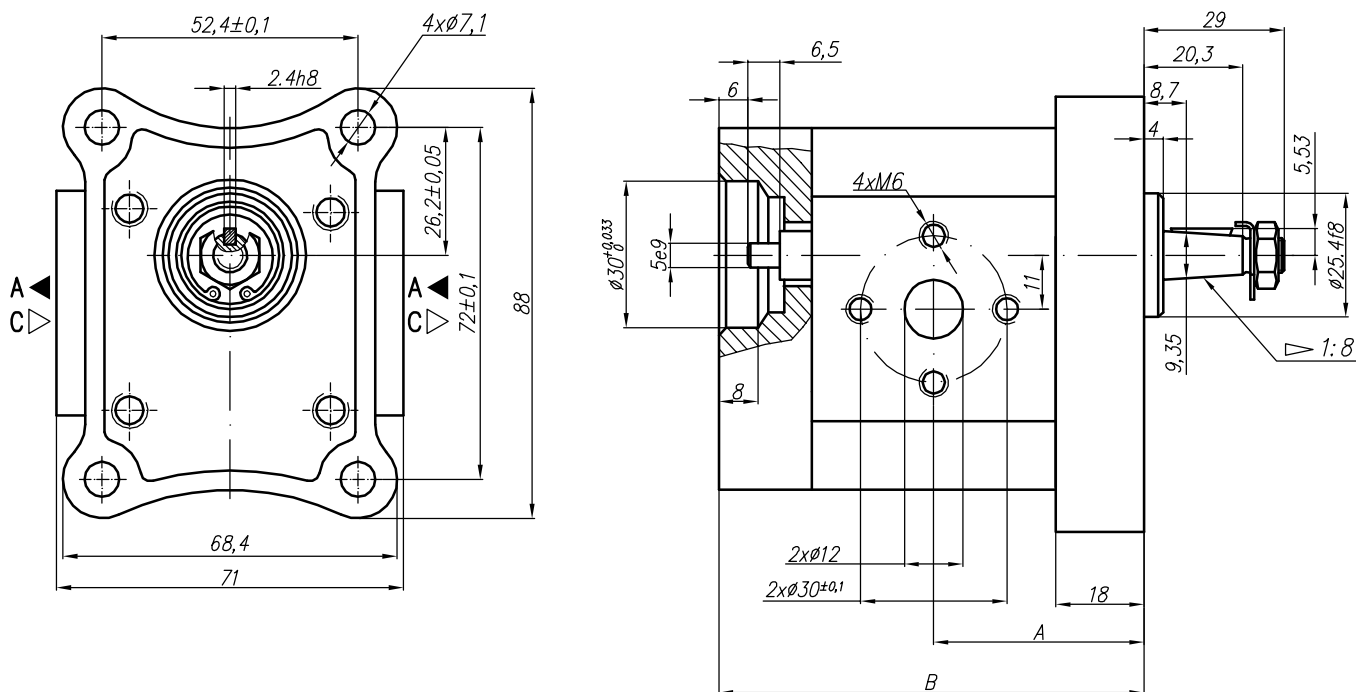

Type	Displacement cm ³ /rev	Flow		Pressure P _{nom} bar	max Speed n rpm	Dimension							
		at 1500 rpm l/min	at max rpm l/min			Inlet			Outlet				
						A mm	B mm	E	F	d	E	F	d
10A(C)1X576	1	1,40	3,26	250	3500	39,1	79,1	Ø30	Ø12	M6	Ø30	Ø12	M6
10A(C)1,25X576	1,25	1,74	4,07	250	3500	39,5	80,1						
10A(C)1,6X576	1,6	2,23	5,21	250	3500	40,3	81,5						
10A(C)2X576	2	2,82	6,58	250	3500	41,1	83,2						
10A(C)2,5X576	2,5	3,53	8,23	250	3500	42,1	85,2						
* 10A(C)2,65X576	2,65	3,74	8,72	250	3500	42,4	85,8						
10A(C)3,15X576	3,15	4,44	10,36	250	3500	43,5	87,8						
10A(C)3,65X576	3,65	5,15	12,01	250	3500	44,4	89,8						
10A(C)4,2X576	4,2	5,92	13,82	250	3500	45,5	92						
* 10A(C)4,7X576	4,7	6,63	15,46	250	3500	46,1	94,1						
10A(C)5X576	5	7,05	16,45	250	3500	47,1	95,2						
10A(C)5,7X576	5,7	8,12	16,25	200	3000	48,5	98						
10A(C)6,1X576	6,1	8,69	14,49	180	2500	49,4	99,8						
10A(C)7,4X576	7,4	10,55	17,58	180	2500	52,1	105,2						
* 10A(C)8X576	8	11,40	15,20	150	2000	53,4	107,7						
10A(C)8,5X576	8,5	12,11	16,15	150	2000	54,4	109,8						
10A(C)9,8X576	9,8	13,97	18,62	120	2000	57	115						

* - These pumps - only under a special order

The pump 10A(C)...X579 is a second section of multiple pump Gr.21.

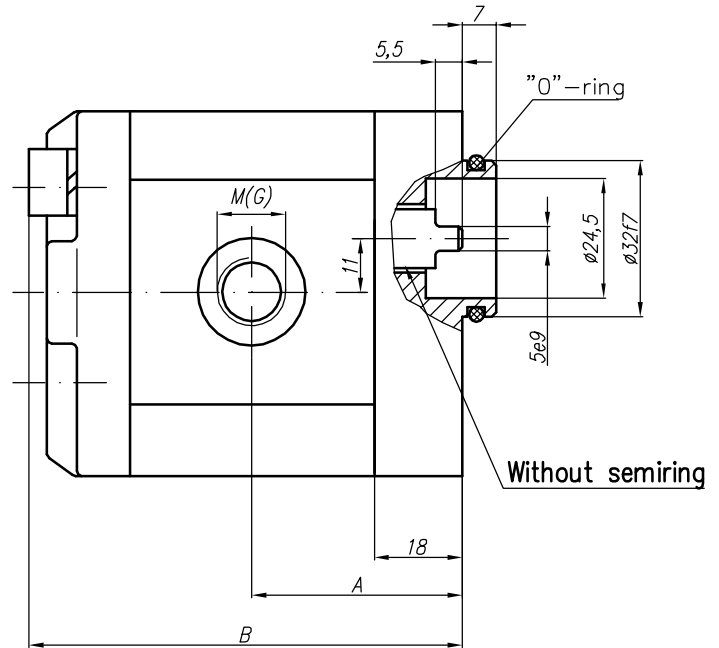
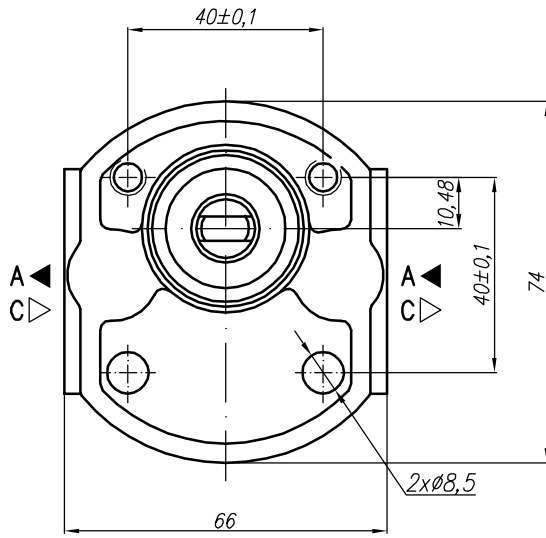

Variants:

...X579M - for M ports (see the table);

...X579G - for G ports (see the table).

Type	Displacement cm ³ /rev	Flow		Pressure P _{nom} bar	max Speed n rpm	Dimension												
		at 1500 rpm l/min	at max rpm l/min			A mm	B mm	Inlet			Outlet							
								M	G	U	M	G	U					
10A(C)1X579	1	1,40	3,26	250	3500	39,1	81	M18x1,5	G 3/8" - A		M14x1,5	G 3/8" - A						
10A(C)1,25X579	1,25	1,74	4,07	250	3500	39,5	82											
10A(C)1,6X579	1,6	2,23	5,21	250	3500	40,3	83,6											
10A(C)2X579	2	2,82	6,58	250	3500	41,1	85,2											
10A(C)2,5X579	2,5	3,53	8,23	250	3500	42,1	87,2											
* 10A(C)2,65X579	2,65	3,74	8,72	250	3500	42,4	87,8											
10A(C)3,15X579	3,15	4,44	10,36	250	3500	43,5	89,8											
10A(C)3,65X579	3,65	5,15	12,01	250	3500	44,4	91,9											
10A(C)4,2X579	4,2	5,92	13,82	250	3500	45,5	94,1											
* 10A(C)4,7X579	4,7	6,63	15,46	250	3500	46,1	96											
10A(C)5X579	5	7,05	14,10	250	3000	47,1	97,2	G 1/2" - A			G 3/8" - A							
10A(C)5,7X579	5,7	8,12	16,25	200	3000	48,5	100,1											
10A(C)6,1X579	6,1	8,69	14,49	200	2500	49,4	101,8											
10A(C)7,4X579	7,4	10,55	17,58	180	2500	52,1	107,2											
* 10A(C)8X579	8	11,40	15,20	150	2000	53,4	109,7											
10A(C)8,5X579	8,5	12,11	16,15	150	2000	54,4	111,7											
10A(C)9,8X579	9,8	13,97	18,62	120	2000	57	117											
													M22x1,5			M18x1,5		

* - These pumps - only under a special order

The pump 10A(C)...X594 is a middle section of a multiple pump gr. 111.

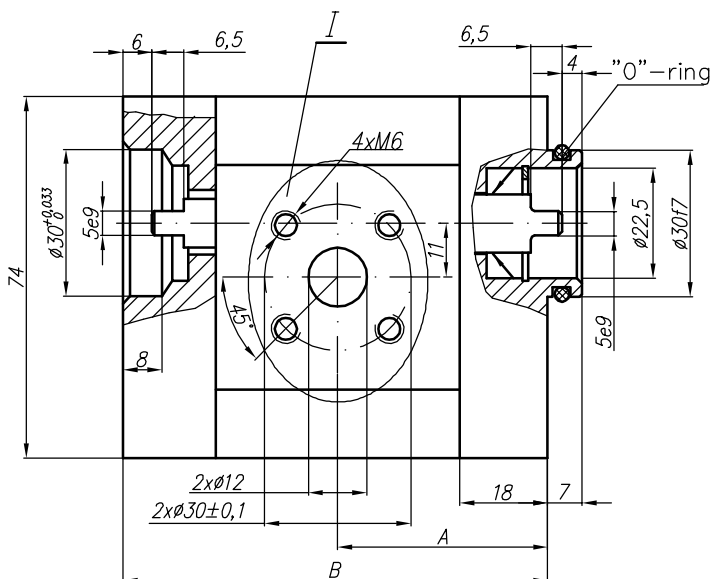
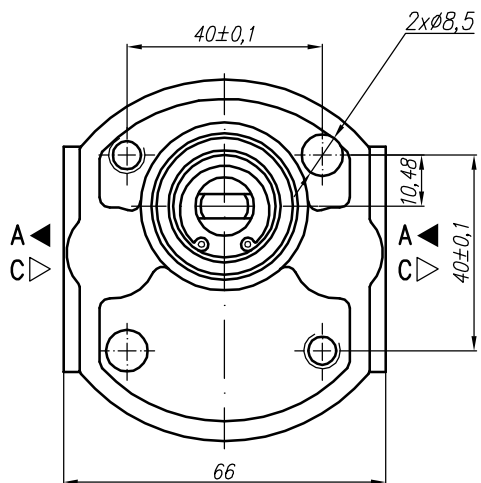

I – variants

Variants:

- ...X594 - Normal version (flange);
- ...X594M - for M ports (see the picture I and the table below);
- ...X594G - for G ports (see the picture I and the table below);
- ...X594U - for U ports (see the picture I and the table below).

Variant M

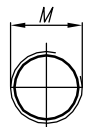

Variant G

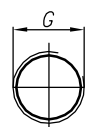

Variant U (SAEJ475 (ISO R725))

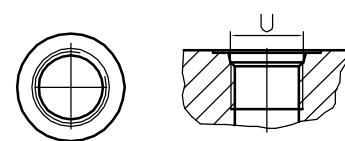

Type	Displacement cm ³ /rev	Flow		Pressure P _{nom} bar	max Speed n rpm	Dimension							
		at 1500 rpm l/min	at max rpm l/min			A mm	B mm	Inlet			Outlet		
								M	G	U	M	G	U
10A(C)1X594	1	1,40	3,26	250	3500	39,1	79	M16x1,5	G 3/8" - A	3/4" - 16UNF - 2B	M16x1,5	G 3/8" - A	9/16" - 18UNF - 2B
10A(C)1,25X594	1,25	1,74	4,07	250	3500	39,5	80						
10A(C)1,6X594	1,6	2,23	5,21	250	3500	40,3	81,6						
10A(C)2X594	2	2,82	6,58	250	3500	41,1	83,2						
10A(C)2,5X594	2,5	3,53	8,23	250	3500	42,1	85,2						
* 10A(C)2,65X594	2,65	3,74	8,72	250	3500	42,4	85,8	M20x1,5	G 1/2" - A	3/4" - 16UNF - 2B	M16x1,5	G 3/8" - A	9/16" - 18UNF - 2B
10A(C)3,15X594	3,15	4,44	10,36	250	3500	43,5	87,8						
10A(C)3,65X594	3,65	5,15	12,01	250	3500	44,4	89,9						
10A(C)4,2X594	4,2	5,92	13,82	250	3500	45,5	92,1						
* 10A(C)4,7X594	4,7	6,63	15,46	250	3500	46,1	94						
10A(C)5X594	5	7,05	14,10	250	3000	47,1	95,2	M22x1,5	G 1/2" - A	7/8" - 14UNF	M18x1,5	G 3/8" - A	3/4" - 16UNF
10A(C)5,7X594	5,7	8,12	16,25	200	3000	48,5	98,1						
10A(C)6,1X594	6,1	8,69	14,49	200	2500	49,4	99,8						
10A(C)7,4X594	7,4	10,55	17,58	180	2500	52,1	105,2						
* 10A(C)8X594	8	11,40	15,20	150	2000	53,4	107,7						
10A(C)8,5X594	8,5	12,11	16,15	150	2000	54,4	109,7	M22x1,5	G 1/2" - A	7/8" - 14UNF	M18x1,5	G 3/8" - A	3/4" - 16UNF
10A(C)9,8X594	9,8	13,97	18,62	120	2000	57	115						

* - These pumps - only under a special order

Rotation "A" - (anticlockwise)

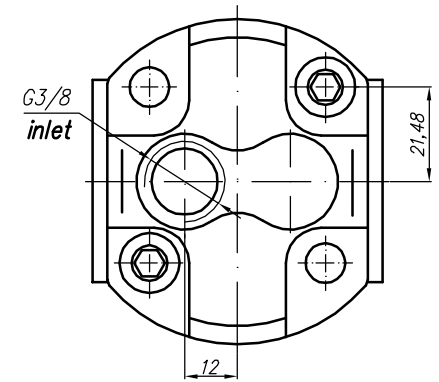
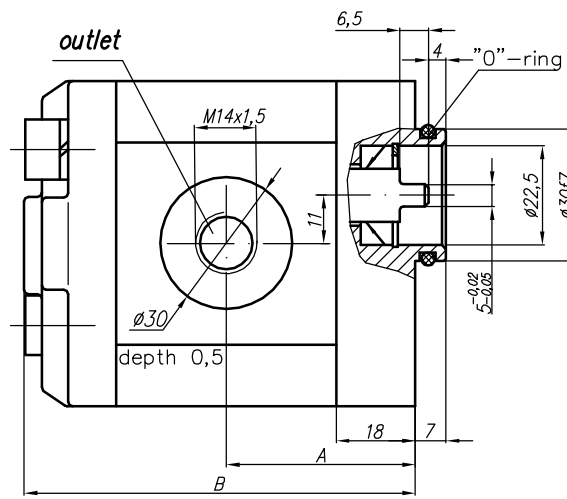
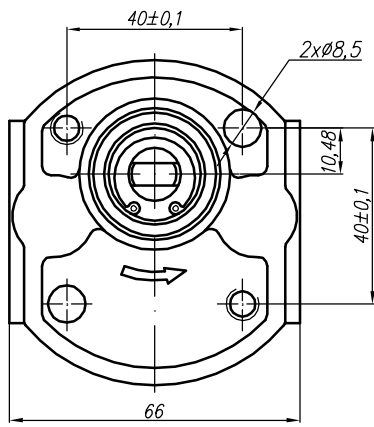

Rotation "A" - (clockwise)

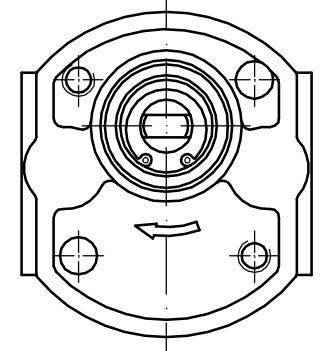
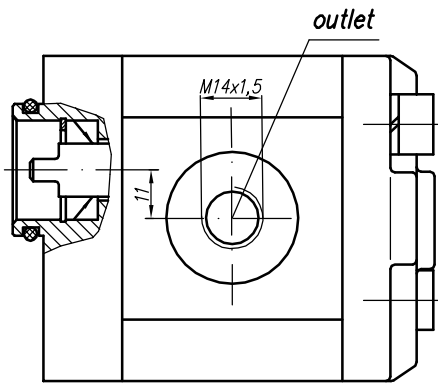
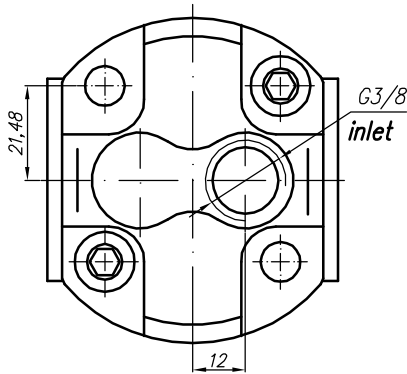

Type	Displacement cm ³ /rev	Flow		Pressure P _{nom} bar	max Speed n rpm	Dimension							
		at 1500 rpm l/min	at max rpm l/min			Inlet			Outlet				
						A mm	B mm	M	G	U	M	G	U
10A(C)1X649	1	1,40	3,26	250	3500	39,1	81	G 3/8" - A			M14x1,5		
10A(C)1,25X649	1,25	1,74	4,07	250	3500	39,5	82						
10A(C)1,6X649	1,6	2,23	5,21	250	3500	40,3	83,6						
10A(C)2X649	2	2,82	6,58	250	3500	41,1	85,2						
10A(C)2,5X649	2,5	3,53	8,23	250	3500	42,1	87,2						
* 10A(C)2,65X649	2,65	3,74	8,72	250	3500	42,4	87,8						
10A(C)3,15X649	3,15	4,44	10,36	250	3500	43,5	89,8						
10A(C)3,65X649	3,65	5,15	12,01	250	3500	44,4	91,9						
10A(C)4,2X649	4,2	5,92	13,82	250	3500	45,5	94,1						
* 10A(C)4,7X649	4,7	6,63	15,46	250	3500	46,1	96						
10A(C)5X649	5	7,05	16,45	250	3500	47,1	97,2						
10A(C)5,7X649	5,7	8,12	16,25	200	3000	48,5	100,1						
10A(C)6,1X649	6,1	8,69	14,49	180	2500	49,4	101,8						
10A(C)7,4X649	7,4	10,55	17,58	180	2500	52,1	107,2						
* 10A(C)8X649	8	11,40	15,20	150	2000	53,4	109,7						
10A(C)8,5X649	8,5	12,11	16,15	150	2000	54,4	111,7						
10A(C)9,8X649	9,8	13,97	18,62	120	2000	57	117						

* - These pumps - only under a special order